



Moving Forward Working Together

AGENDA

April 29, 2024

Regular Meeting – 6:00 P.M.

- Call to Order
- Pledge of Allegiance
- Roll Call
- Moment of Silence – Past President Carl Palmateer (Terms: 2007-2018)
- Review Minutes of Regular Meeting of March 25, 2024 – page 3
- Review Financial Statement ending March 31, 2024 – page 7
- Citizen Comments
- Budget and Finance
 - Approval of Bills
 - First Quarter Budget Amendment – page 31
 - Approval of Sun Life Insurance Proposal – page 67
 - Approve Marketing RFP Recommendation – page 79
- Public Services Committee
 - Approve Quote from Dean Alexander Concrete for Sidewalk Repair – page 81
 - Approve Purchase of Salt Truck Chassis through MIDEAL Program – page 83
 - Approve Purchase of Equipment for New Salt Truck – page 97
- Personnel and Public Safety
 - Appoint Memorial Day Parade Chairperson
- Parks and Recreation Committee
 - Approve Purchase of Pool Chemicals for 2024 season – page 101
 - Approve Purchase of Pool Vacuum from Grant Funding – page 103
- Downtown Development Authority– Minutes of March 12, 2024 Minutes – page 107
- Economic Development Corporation – Minutes of March 12, 2024 Minutes – page 109
- Planning Commission– Minutes of February 21, 2024 Minutes – page 111
- Manager's Report – page 113
- Communications
 - Petition for Chickens and Two Goats from Laura Gaeth – page 115
 - Petition for Chickens from Drew Wessels – page 121
- Other Business
 - **Closed Session**, in accordance with the Open Meetings Act 267 of 1976, Section 15.268, Sec. 8 (c) for strategy and negotiation sessions connected with the negotiation of a collective bargaining agreement.
- Adjournment

May 2024 Meetings and Events:

May 8 – Personnel & Public Safety Committee, 4 pm

May 8 – Committee of the Whole, 7 pm

May 14 – DDA/EDC Meeting, 1:30 pm

May 14 – Parks and Recreation Committee, 4 pm

May 15 – Public Services Committee, 12 pm

May 15 – Planning Commission, 7 pm

May 20 – Budget & Finance Committee, 5 pm

May 20 – Council Meeting, 6 pm (Note: Date Change due to Memorial Day Holiday on May 27th)

May 27 – Memorial Day, Offices Closed

May 27 – Memorial Day Parade begins at 10:00 am

A Regular Meeting of the Cass City Village Council was held at the Cass City Municipal Building on Monday, March 25, 2024, at 6:00 p.m. Council Members present: President Robert Piaskowski, Trustees: Jeffrey Benkelman, Kevven Dorland, Bill Hartzell, Michael Kirn and Joe Leeson.

Barbara Kirn, spokesman for the Cass City Historical Museum, gave a presentation on the history and future vision for the Cass City Cultural Center. During the 75 minutes of active dialog, Cultural Supporters Nancy Barrios, Jenny Zawilinski added comments to Ms. Kirn's overview. Michael Klinessmith, Tuscola Economic Development Corporation, detailed a grant opportunity for rehabilitation of the building. Tuscola EDC and the Cass City Historical Museum supporters strongly requested support from the Village Council for application for the Cultural Center Rehabilitation project.

During Citizen's Comments, Don Ball, 6328 Main Street, inquired on local anti-blight efforts, and actions for realtor listing of village owned vacant properties.

MOTION# 2024.3.25-01

MOTION by Trustee Kirn, Supported by Trustee Griesing to receive, approve, and file the minutes of the February 26, 2024 Regular Meeting. MOTION CARRIED 7 yeas 0 nays

MOTION# 2024.3.25-02

MOTION by Trustee Leeson, Supported by Trustee Griesing to receive, and accept the Financial Statements of February 29, 2024. MOTION 7 yeas 0 nays

MOTION# 2024.3.25-03

MOTION by Trustee Leeson, Supported by Trustee Benkelman, to receive and file the Village of Cass City Accounts Payable paid invoices. MOTION CARRIED 7 yeas 0 nays

MOTION# 2024.3.25-04

MOTION by Trustee Leeson, Supported by Trustee Benkelman, to commit the Village of Cass City as responsible party for costs and overages related to the rehabilitation of the former Elkland Township Hall, that fall outside of the funding application to the Blight Elimination Program, and may not otherwise be covered by private sources including funds raised by the Cass City Cultural Historical Center, the Cass City Downtown Development Authority (DDA) and/or private sources of funding. Roll Call Vote: Benkelman: yea, Dorland: yea, Griesing: no, Hartzell: no, Kirn: yea, Leeson: yea, Piaskowski: no. MOTION CARRIED 4 yeas 3 nays

MOTION# 2024.3.25-05

MOTION by Trustee Hartzell, Supported by Trustee Dorland, to authorize Debora Powell, Village Manager to negotiate with Elite Realty to list 2 parcels (8.08 acre parcel and 4.2 acre parcel) located in the Cass City Industrial Park. Roll Call Vote: Benkelman: yea, Dorland: yea, Griesing: yea, Hartzell: yea, Kirn: yea, Leeson: yea, Piaskowski: yea. MOTION CARRIED 7 yeas 0 nays

MOTION# 2024.3.25-06

MOTION by Trustee Griesing, Supported by Trustee Hartzell, to authorize Deboria Powell, Village Manager to enter into an agreement with Elite Realty to list 2 Village owned parcels on Third Street for a six month period, with legal advice on municipal land sale process. Roll Call Vote: Benkelman: yea, Dorland: yea, Griesing: yea, Hartzell: yea, Kirn: yea, Leeson: yea, Piaskowski: yea. MOTION CARRIED 7 yeas 0 nays

MOTION# 2024.3.25-07

MOTION by Trustee Leeson, Supported by Trustee Hartzell, to approve Lease Agreement with Cass City Chamber of Commerce for office space in the Cass City Municipal Building for two years beginning April 1, 2024 through April 1, 2026 with monthly rent of \$125 in 2024, and \$150 in 2025 and 2026. MOTION CARRIED 7 yeas 0 nays.

MOTION# 2024.3.25-08

MOTION by Trustee Kirn, Supported by Trustee Griesing, to approve the low bid by Astec Asphalt Inc, for the 2024 Church St. and Sherman St. asphalt work in the amount of \$129,402 plus a 10% contingency. MOTION CARRIED 7 yeas 0 nays

MOTION# 2024.3.25-09

MOTION by Trustee Kirn, Supported by Trustee Leeson, to approve the sole bid by Fahrner Asphalt Sealers for the 2024 Huron St. - Chip and Fog, in the amount of \$22,932 plus a 10% contingency. MOTION CARRIED 7 yeas 0 nays

MOTION# 2024.3.25-10

MOTION by Trustee Hartzell, Supported by Trustee Leeson, to authorize Village Manager Debbie Powell and Utilities Director RJ Klaus to negotiate additional street work for up to \$37,000 for Street Chip and Fog and up to \$95,000 for Street Asphalt work, each with a 10% contingency. MOTION CARRIED 7 yeas 0 nays

MOTION# 2024.3.25-11

MOTION by Trustee Kirn, Supported by Trustee Leeson, to approve Professional Services Agreement with SAFEbuilt Michigan, LLC for Code Enforcement Services, as needed, at a rate of \$85 per hour. MOTION CARRIED 7 yeas 0 nays

MOTION# 2024.3.25-12

MOTION by Trustee Hartzell, Supported by Trustee Benkelman, to approve the Village of Cass City Administrative Policy for Worker's Compensation Benefits. MOTION CARRIED 7 yeas 0 nays

MOTION# 2024.3.25-13

MOTION by Trustee Hartzell, Supported by Trustee Benkelman, to approve the Village of Cass City Administrative Policy for Unpaid Leave of Absence. MOTION CARRIED 7 yeas 0 nays

MOTION# 2024.3.25-14

MOTION by Trustee Dorland, Supported by Trustee Kirn, to receive and file the minutes of the Cass City Downtown Development Authority (DDA) held on February 13, 2024. MOTION CARRIED 7 years 0 nays

MOTION# 2024.3.25-15

MOTION by Trustee Benkelman, Supported by Trustee Kirn, to receive and file the minutes of the Cass City Economic Development Corporation (EDC) held on February 13, 2024. MOTION CARRIED 7 years 0 nays

MOTION# 2024.3.25-16

MOTION by Trustee Benkelman, Supported by Trustee Leeson, to receive and file the minutes of the Cass City Planning Commission held on February 21, 2024. MOTION CARRIED 7 years 0 nays

MOTION# 2024.3.25-17

MOTION by Trustee Leeson, Supported by Trustee Benkelman, to receive and file the 2023 Cass City Planning Commission Annual Report. MOTION CARRIED 7 years 0 nays

The Manager's Report was reviewed.

MOTION# 2024.3.25-18

MOTION by Trustee Benkelman, Supported by Trustee Dorland, to adjourn the meeting at 8: 21 pm. MOTION CARRIED 7 years 0 nays

Nanette S. Walsh

Nanette Walsh, CMC, CPFA, CPFIM, MiCPT

Village of Cass City

Financial Statements

Month Ending 3/31/24

25% of Fiscal Year

GL NUMBER	DESCRIPTION	2024 AMENDED BUDGET	ACTIVITY FOR MONTH 03/31/24 INCR (DECR)	YTD BALANCE 03/31/2024 NORM (ABNORM)	ENCUMBERED YEAR-TO-DATE	UNENCUMBERED BALANCE	% BDTG USED
Fund 101 - GENERAL FUND							
101-000-402.000	REAL PROPERTY TAXES	648,874.00	0.00	0.00	0.00	648,874.00	0.00
101-000-404.000	REAL PROPERTY TX-PA359 (PROMOTIONS)	36,360.00	0.00	0.00	0.00	36,360.00	0.00
101-000-410.000	PERSONAL PROPERTY TAXES	58,070.00	0.00	0.00	0.00	58,070.00	0.00
101-000-418.000	PER PROP TAX-PA 359 (PROMOTIONS)	3,182.00	0.00	0.00	0.00	3,182.00	0.00
101-000-445.000	PENALTIES & INTEREST TAXES	150.00	0.00	0.00	0.00	150.00	0.00
101-000-447.000	COLLECTION FEES TAXES	10,586.00	0.00	0.00	0.00	10,586.00	0.00
101-000-451.000	LIQUOR LICENSE FEES	2,000.00	0.00	0.00	0.00	2,000.00	0.00
101-000-543.000	STATE GRANT-PA 302 FUNDS	927.00	0.00	0.00	0.00	927.00	0.00
101-000-573.000	LOCAL COMM STABILIZATION SHARE (LCAS)	200,058.00	0.00	0.00	0.00	200,058.00	0.00
101-000-574.000	STATE SHARED REVENUE	316,140.00	0.00	0.00	0.00	316,140.00	0.00
101-000-575.000	STATE SHARED REV, EVIP	59,414.00	0.00	0.00	0.00	59,414.00	0.00
101-000-581.000	REVENUES, CCPS; SCHOOL.RESOURCE.OFFICER	68,000.00	18,036.33	19,545.77	0.00	48,454.23	28.74
101-000-584.000	RESTITUTION FUNDS, CCPD	100.00	0.00	0.00	0.00	100.00	0.00
101-000-607.000	CABLE FRANCHISE FEES	36,050.00	0.00	0.00	0.00	36,050.00	0.00
101-000-608.000	ZONING PERMIT FEES	5,000.00	60.00	155.00	0.00	4,845.00	3.10
101-000-609.000	RENTAL REGISTRATION FEES	1,000.00	0.00	0.00	0.00	1,000.00	0.00
101-000-625.000	MISCELLANEOUS REVENUES	2,600.00	101.00	306.00	0.00	2,294.00	11.77
101-000-640.000	REFUSE FEES	170,959.00	13,035.60	26,049.88	0.00	144,909.12	15.24
101-000-651.000	SWIMMING FEES	60,000.00	155.00	155.00	0.00	59,845.00	0.26
101-000-652.000	ARTS / CRAFTS FEES	10,000.00	0.00	0.00	0.00	10,000.00	0.00
101-000-653.000	OTHER RECREATION FEES	2,800.00	0.00	520.00	0.00	2,280.00	18.57
101-000-655.000	ORDINANCE FINES	1,500.00	310.16	919.41	0.00	580.59	61.29
101-000-662.000	REFUSE PENALTIES	3,500.00	248.60	705.82	0.00	2,794.18	20.17
101-000-664.000	INTEREST & DIVIDENDS	18,000.00	1,638.71	2,082.79	0.00	15,917.21	11.57
101-000-671.000	MISCELLANEOUS REIMBURSEMENT	4,500.00	78.09	384.09	0.00	4,115.91	8.54
101-000-674.000	POOL DONATIONS/SPONSORSHIPS	250.00	0.00	0.00	0.00	250.00	0.00
101-000-675.000	DONATIONS FROM PUBLIC & PRIVATE	11,000.00	2,989.17	2,989.17	0.00	8,010.83	27.17
101-000-676.000	DOG PARK DONATIONS	0.00	0.00	141.00	0.00	(141.00)	100.00
101-000-678.000	DONATIONS, MUSIC IN THE PARK	2,500.00	800.00	800.00	0.00	1,700.00	32.00
101-000-699.000	TRANSFERS IN, ADMIN CHRG	203,664.00	0.00	0.00	0.00	203,664.00	0.00
101-000-699.100	TRANSFER IN FROM FUND BALANCE	85,000.00	0.00	0.00	0.00	85,000.00	0.00
101-000-699.300	TRANSFER IN FROM FB, COMM PROMO	7,500.00	0.00	0.00	0.00	7,500.00	0.00
101-000-699.400	TRANSFER IN FROM FB, DOG PARK.	2,500.00	0.00	0.00	0.00	2,500.00	0.00

Fund 101 - GENERAL FUND:

TOTAL REVENUES 2,032,184.00 37,452.66 54,753.93 0.00 1,977,430.07 2.69

GL NUMBER	DESCRIPTION	2024 AMENDED BUDGET	ACTIVITY FOR MONTH 03/31/24 INCR (DECR)	YTD BALANCE 03/31/2024 NORM (ABNORM)	ENCUMBERED YEAR-TO-DATE	UNENCUMBERED BALANCE	% BDGT USED
Fund 101 - GENERAL FUND							
101 - COUNCIL		7,700.00	0.00	136.71	0.00	7,563.29	1.78
172 - ADMINISTRATIVE		168,561.00	13,884.61	39,814.97	0.00	128,746.03	23.62
215 - CLERK STAFF		218,499.00	12,761.00	42,457.50	0.00	176,041.50	19.43
223 - FINANCE		21,115.00	0.00	0.00	0.00	21,115.00	0.00
261 - GENERAL GOVERNMENT		129,819.00	5,445.49	19,560.57	0.00	110,258.43	15.07
262 - ELECTIONS		103.00	0.00	0.00	0.00	103.00	0.00
265 - BUILDINGS & GROUNDS		38,254.00	2,523.03	7,300.50	0.00	30,953.50	19.08
291 - COMMUNITY PROMOTION (PA 359)		53,828.00	9,584.96	17,785.95	23.72	36,018.33	33.09
301 - POLICE DEPARTMENT		682,152.00	51,924.74	180,456.74	1,539.00	500,156.26	26.68
315 - CRIME & SAFETY		11,000.00	0.00	0.00	0.00	11,000.00	0.00
401 - MISC GOVERNMENT		13,500.00	0.00	0.00	0.00	13,500.00	0.00
441 - PUBLIC WORKS		24,211.00	109.79	120.74	0.00	24,090.26	0.50
520 - SOLID WASTE DISPOSAL		170,959.00	13,023.78	38,890.94	0.00	132,068.06	22.75
722 - PLANNING AND ZONING		61,703.00	5,051.20	15,634.08	0.00	46,068.92	25.34
752 - SWIMMING POOL		162,114.00	627.47	785.57	0.00	161,328.43	0.48
754 - PARKS DEPARTMENT		250,773.00	15,640.43	57,610.00	5,639.17	187,523.83	25.22
758 - RECREATION / DAYCAMP		17,893.00	25.32	360.96	0.00	17,532.04	2.02
Fund 101 - GENERAL FUND:		2,032,184.00	130,601.82	420,915.23	7,201.89	1,604,066.88	21.07
TOTAL EXPENDITURES							

REVENUE REPORT

PERIOD ENDING 03/31/2024

% Fiscal Year Completed: 24.86

User: NAN
DB: Cass City

GL NUMBER	DESCRIPTION	2024 AMENDED BUDGET	2024 MONTH 03/31/24 ACTIVITY FOR INCR (DECR)	YTD BALANCE 03/31/2024 NORM (ABNORM)	ENCUMBERED YEAR-TO-DATE	UNENCUMBERED BALANCE	% BGDGT USED
Fund 202 - MAJOR STREET							
202-000-402.000	MJ ST REAL PROPERTY TAXES	27,398.00	0.00	0.00	0.00	27,398.00	0.00
202-000-410.000	MJ ST PERSONAL PROPERTY TAXES	2,300.00	0.00	0.00	0.00	2,300.00	0.00
202-000-553.000	MJ ST GAS & WEIGHT	284,485.00	23,205.82	23,205.82	0.00	261,279.18	8.16
202-000-573.000	LOCAL COMM STABILIZATION SHARE (LCAS)	7,088.00	0.00	0.00	0.00	7,088.00	0.00
202-000-607.000	PA 48 METRO ACT, TELECOM RT OF WAY	14,075.00	0.00	0.00	0.00	14,075.00	0.00
202-000-664.000	INTEREST & DIVIDENDS	7,000.00	1,874.14	2,338.01	0.00	4,661.99	33.40
202-000-671.000	MJ ST MISC. REIMBURSEMENT	6,700.00	0.00	0.00	0.00	6,700.00	0.00
202-000-676.000	TRUNK LINE MAINTENANCE CONTRACT	49,592.00	0.00	0.00	0.00	49,592.00	0.00
202-000-690.000	MJ ST 1.5 MILLS CO. BRIDGE TAX	32,328.00	0.00	0.00	0.00	32,328.00	0.00
202-000-691.000	APPROPRIATION FROM GENERAL FUND	117,000.00	0.00	0.00	0.00	117,000.00	0.00

Fund 202 - MAJOR STREET:	547,966.00	25,079.96	25,543.83	0.00	522,422.17	4.66
TOTAL REVENUES						

GL NUMBER	DESCRIPTION	2024 AMENDED BUDGET	ACTIVITY FOR MONTH 03/31/24 INCR (DECR)	YTD BALANCE 03/31/2024 NORM (ABNORM)	ENCUMBERED YEAR-TO-DATE	UNENCUMBERED BALANCE	% BDTG USED
Fund 202 - MAJOR STREET							
463 - STREET MAINTENANCE		316,214.00	1,904.54	8,455.86	115,071.26	192,686.88	39.06
470 - R. O. W. MAINTENANCE		42,549.00	0.00	4.20	0.00	42,544.80	0.01
474 - SIGNS		7,234.00	0.00	1,675.45	0.00	5,558.55	23.16
478 - SNOW		99,495.00	2,935.55	14,695.00	0.00	84,800.00	14.77
486 - TRUNKLINE MAINTENANCE		6,666.00	0.00	321.96	0.00	6,344.04	4.83
488 - TRUNKLINE SWEEPING/FLUSHING		12,287.00	0.00	418.04	0.00	11,868.96	3.40
493 - STATE MONUMENT PROPERTY T.I.		1,271.00	0.00	0.00	0.00	1,271.00	0.00
494 - TRUNKLINE UTILITIES		11,827.00	41.49	85.53	0.00	11,741.47	0.72
497 - TRUNKLINE SNOW REMOVAL		41,986.00	1,625.18	20,900.35	1,185.95	19,899.70	52.60
502 - TRUNKLINE FRINGE BENEFITS		8,437.00	41.98	2,307.05	0.00	6,129.95	27.34
<div style="text-align: center;"> 1 1 1 </div>							
Fund 202 - MAJOR STREET:		547,966.00	6,548.74	48,863.44	116,257.21	382,845.35	30.13
TOTAL EXPENDITURES							

PERIOD ENDING 03/31/2024
 % Fiscal Year Completed: 24.86

GL NUMBER	DESCRIPTION	2024 AMENDED BUDGET	ACTIVITY FOR		YTD BALANCE 03/31/2024 NORM (ABNORM)	ENCUMBERED YEAR-TO-DATE	UNENCUMBERED BALANCE	% BDGT	
			MONTH 03/31/24 INCR (DECR)	03/31/2024 NORM (ABNORM)				USED	USED
Fund 203 - LOCAL STREET									
203-000-402.000	REAL PROPERTY TAXES	236,255.00	0.00	0.00	0.00	0.00	236,255.00	0.00	0.00
203-000-410.000	PERSONAL PROPERTY TAXES	23,699.00	0.00	0.00	0.00	0.00	23,699.00	0.00	0.00
203-000-553.000	GAS & WEIGHT	112,050.00	8,957.59	8,957.59	8,957.59	0.00	103,092.41	7.99	7.99
203-000-573.000	LOCAL COMM STABILIZATION SHARE (LCAS)	63,841.00	0.00	0.00	0.00	0.00	63,841.00	0.00	0.00
203-000-664.000	INTEREST & DIVIDENDS	10,000.00	2,574.26	3,281.85	3,281.85	0.00	6,718.15	32.82	32.82
203-000-671.000	MISC REIMBURSEMENTS	2,621.00	0.00	0.00	0.00	0.00	2,621.00	0.00	0.00
203-000-690.000	1.5 MILLS CO. BRIDGE TAX	46,732.00	0.00	0.00	0.00	0.00	46,732.00	0.00	0.00
203-000-699.000	TRANSFER IN, LOCAL STREET FUND BALANCE	10,000.00	0.00	0.00	0.00	0.00	10,000.00	0.00	0.00
Fund 203 - LOCAL STREET:									
TOTAL REVENUES		505,198.00	11,531.85	12,239.44	12,239.44	0.00	492,958.56	2.42	2.42

EXPENDITURE REPORT

PERIOD ENDING 03/31/2024
 % Fiscal Year Completed: 24.86

GL NUMBER	DESCRIPTION	2024 AMENDED BUDGET	ACTIVITY FOR MONTH 03/31/24 INCR (DECR)	YTD BALANCE 03/31/2024 NORM (ABNORM)	ENCUMBERED YEAR-TO-DATE	UNENCUMBERED BALANCE	% BDGT USED
Fund 203 - LOCAL STREET							
463	STREET MAINTENANCE	302,823.00	19,128.39	47,744.55	75,646.49	179,431.96	40.75
470	R. O. W. MAINTENANCE	42,123.00	0.00	0.00	0.00	42,123.00	0.00
474	SIGNS	7,633.00	0.00	0.00	0.00	7,633.00	0.00
478	SNOW	65,332.00	1,888.43	13,955.54	1,604.52	49,771.94	23.82
494	TRUNKLINE UTILITIES	85,912.00	6,680.78	13,463.81	0.00	72,448.19	15.67
Fund 203 - LOCAL STREET:							
TOTAL EXPENDITURES		503,823.00	27,697.60	75,163.90	77,251.01	351,408.09	30.25

PERIOD ENDING 03/31/2024
 % Fiscal Year Completed: 24.86

GL NUMBER	DESCRIPTION	2024 AMENDED BUDGET	ACTIVITY FOR MONTH 03/31/24 INCR (DECR)	YTD BALANCE 03/31/2024 NORM (ABNORM)	ENCUMBERED YEAR-TO-DATE	UNENCUMBERED BALANCE	% BDGT USED
Fund 244 - ECONOMIC DEVELOPMENT							
244-000-664.000	INTEREST & DIVIDENDS	300.00	0.42	1.72	0.00	298.28	0.57
244-000-691.000	APPROPRIATION FROM FUND BALANCE	3,800.00	0.00	0.00	0.00	3,800.00	0.00
244-000-692.000	CONTRIBUTION FROM GENERAL FUND	13,500.00	0.00	0.00	0.00	13,500.00	0.00

Fund 244 - ECONOMIC DEVELOPMENT:

TOTAL REVENUES 17,600.00 0.42 1.72 0.00 17,598.28 0.01

PERIOD ENDING 03/31/2024
 % Fiscal Year Completed: 24.86

GL NUMBER	DESCRIPTION	2024 AMENDED BUDGET	ACTIVITY FOR MONTH 03/31/24 INCR (DECR)	YTD BALANCE 03/31/2024 NORM (ABNORM)	ENCUMBERED YEAR-TO-DATE	UNENCUMBERED BALANCE	% BDGT USED
Fund 244 - ECONOMIC DEVELOPMENT							
001 - ADMINISTRATION		17,600.00	1,125.18	8,375.54	0.00	9,224.46	47.59

Fund 244 - ECONOMIC DEVELOPMENT:

TOTAL EXPENDITURES

17,600.00	1,125.18	8,375.54	0.00	9,224.46	47.59
-----------	----------	----------	------	----------	-------

PERIOD ENDING 03/31/2024
 % Fiscal Year Completed: 24.86

User: NAN
 DB: Cass City

GL NUMBER	DESCRIPTION	2024 AMENDED BUDGET	MONTH 03/31/24	ACTIVITY FOR INCR (DECR)	YTD BALANCE 03/31/2024	NORM (ABNORM)	ENCUMBERED YEAR-TO-DATE	UNENCUMBERED BALANCE	% BDTG USED
Fund 248 - D.D.A.									
248-000-402.000	CAPTURED TAXES	20,677.00		0.00	0.00		0.00	20,677.00	0.00
248-000-403.000	CAPTURE TOWNSHIP TAXES	4,075.00		0.00	0.00		0.00	4,075.00	0.00
248-000-404.000	CAPTURE COUNTY TAXES	9,313.00		0.00	0.00		0.00	9,313.00	0.00
248-000-625.000	MISC FEES	268.00		0.00	0.00		0.00	268.00	0.00
248-000-664.000	INTEREST & DIVIDENDS	361.00		2,920.54	3,812.81		0.00	(3,451.81)	1,056.18
248-000-675.000	TRANSFER FROM FUND BALANCE	2,800.00		0.00	0.00		0.00	2,800.00	0.00
Fund 248 - D.D.A.:									
TOTAL REVENUES		37,494.00		2,920.54	3,812.81		0.00	33,681.19	10.17

GL NUMBER	DESCRIPTION	2024 AMENDED BUDGET	ACTIVITY FOR MONTH 03/31/24 INCR (DECR)	YTD BALANCE 03/31/2024 NORM (ABNORM)	ENCUMBERED YEAR-TO-DATE	UNENCUMBERED BALANCE	% BDGT USED
Fund 248 - D.D.A.							
001 - ADMINISTRATION		27,087.00	3,698.47	10,974.86	0.00	16,112.14	40.52
005 - THORP PROPERTY		600.00	0.00	0.00	0.00	600.00	0.00
008 - DDA DEBT SERVICE		9,807.00	793.35	2,380.05	0.00	7,426.95	24.27
Fund 248 - D.D.A.:							
TOTAL EXPENDITURES		37,494.00	4,491.82	13,354.91	0.00	24,139.09	35.62

PERIOD ENDING 03/31/2024
 % Fiscal Year Completed: 24.86

GL NUMBER	DESCRIPTION	2024 AMENDED BUDGET	ACTIVITY FOR MONTH 03/31/24 INCR (DECR)	YTD BALANCE 03/31/2024 NORM (ABNORM)	ENCUMBERED YEAR-TO-DATE	UNENCUMBERED BALANCE	% BDCGT USED
-----------	-------------	---------------------	---	--------------------------------------	-------------------------	----------------------	--------------

Fund 401 - CAPITAL PROJECTS: SEEGER STREET PROJECT
 401-000-501.000 OTHER LOAN PROCEEDS - USDA/RD

0.00	0.00	0.00	90,000.00	0.00	(90,000.00)	100.00
------	------	------	-----------	------	-------------	--------

Fund 401 - CAPITAL PROJECTS: SEEGER STREET PROJECT:

TOTAL REVENUES	0.00	0.00	90,000.00	0.00	(90,000.00)	100.00
----------------	------	------	-----------	------	-------------	--------

2024 ACTIVITY FOR YTD BALANCE
 MONTH 03/31/24 03/31/2024
 AMENDED BUDGET INCR (DECR) NORM (ABNORM)

ENCUMBERED UNENCUMBERED % BDGT
 YEAR-TO-DATE BALANCE USED

Fund 401 - CAPITAL PROJECTS: SEEGER STREET PROJECT
 001 - ADMINISTRATION

0.00	0.00	0.00	90,150.40	0.00	(90,150.40)	100.00
------	------	------	-----------	------	-------------	--------

Fund 401 - CAPITAL PROJECTS: SEEGER STREET PROJECT:

TOTAL EXPENDITURES	0.00	0.00	90,150.40	0.00	(90,150.40)	100.00
--------------------	------	------	-----------	------	-------------	--------

GL NUMBER	DESCRIPTION	2024 AMENDED BUDGET	ACTIVITY FOR MONTH 03/31/24 INCR (DECR)	YTD BALANCE 03/31/2024 NORM (ABNORM)	ENCUMBERED YEAR-TO-DATE	UNENCUMBERED BALANCE	% BDTG USED
Fund 408 - WATER RECREATION FUND							
408-000-675.000	DONATIONS, SPLASH PARK PROJECT	500.00	0.00	0.00	0.00	500.00	0.00

Fund 408 - WATER RECREATION FUND:

TOTAL REVENUES 500.00 0.00 0.00 0.00 500.00 0.00

User: NAN

PERIOD ENDING 03/31/2024

DB: Cass City

% Fiscal Year Completed: 24.86

ACTIVITY FOR YTD BALANCE
 2024 MONTH 03/31/24 03/31/2024
 INCR (DECR) NORM (ABNORM)

ENCUMBERED UNENCUMBERED % BDGT
 YEAR-TO-DATE BALANCE USED

GL NUMBER	DESCRIPTION	AMENDED BUDGET	INCR (DECR)	2024 MONTH 03/31/24	YTD BALANCE 03/31/2024	NORM (ABNORM)	ENCUMBERED YEAR-TO-DATE	UNENCUMBERED BALANCE	% BDGT USED
Fund 408 - WATER RECREATION FUND									
001 - ADMINISTRATION		500.00	0.00	0.00	0.00	0.00	0.00	500.00	0.00

Fund 408 - WATER RECREATION FUND:

TOTAL EXPENDITURES

500.00	0.00	0.00	0.00	500.00	0.00
--------	------	------	------	--------	------

PERIOD ENDING 03/31/2024
 % Fiscal Year Completed: 24.96

GL NUMBER	DESCRIPTION	2024 AMENDED BUDGET	ACTIVITY FOR MONTH 03/31/24 INCR (DECR)	YTD BALANCE 03/31/2024 NORM (ABNORM)	ENCUMBERED YEAR-TO-DATE	UNENCUMBERED BALANCE	% BDGT USED
Fund 590 - WASTEWATER TREATMENT							
590-000-528.000	OTHER FEDERAL GRANTS - ARPA	245,000.00	0.00	0.00	0.00	245,000.00	0.00
590-000-609.000	SEWER MISC REVENUES	27,810.00	3,760.00	7,315.00	0.00	20,495.00	26.30
590-000-628.000	SEWER OMR FEES	304,707.00	25,700.46	51,441.93	0.00	253,265.07	16.88
590-000-629.000	SEWER USAGE FEES PER 1K GALLONS	530,184.00	41,590.00	83,907.96	0.00	446,276.04	15.83
590-000-636.000	SEWER CONNECTIONS	1,000.00	0.00	0.00	0.00	1,000.00	0.00
590-000-662.000	SEWER SERVICE PENALTIES	15,000.00	1,378.90	3,368.87	0.00	11,631.13	22.46
590-000-664.000	INTEREST & DIVIDENDS	14,500.00	100.80	(76.45)	0.00	14,576.45	(0.53)
590-000-699.000	TRANSFERS FROM FUND BALANCE	33,500.00	0.00	0.00	0.00	33,500.00	0.00
Fund 590 - WASTEWATER TREATMENT:		1,171,701.00	72,530.16	145,957.31	0.00	1,025,743.69	12.46
TOTAL REVENUES							

GL NUMBER	DESCRIPTION	2024 AMENDED BUDGET	ACTIVITY FOR MONTH 03/31/24 INCR (DECR)	YTD BALANCE 03/31/2024 NORM (ABNORM)	ENCUMBERED YEAR-TO-DATE	UNENCUMBERED BALANCE	% BDGT USED
Fund 590 - WASTEWATER TREATMENT							
001 - ADMINISTRATION		238,341.00	8,863.89	29,044.87	0.00	209,296.13	12.19
002 - TREATMENT AND PUMPING		587,852.00	95,909.18	187,678.36	2,298.43	397,875.21	32.32
003 - COLLECTIONS		193,443.00	7,776.33	10,076.61	100,000.00	83,366.39	56.90
004 - MAINTENANCE		151,607.00	12,455.54	42,342.62	0.00	109,264.38	27.93
<hr/>							
Fund 590 - WASTEWATER TREATMENT:		1,171,243.00	125,004.94	269,142.46	102,298.43	799,802.11	31.71
TOTAL EXPENDITURES							

GL NUMBER	DESCRIPTION	2024 AMENDED BUDGET	MONTH 03/31/24 ACTIVITY FOR INCR (DECR)	YTD BALANCE 03/31/2024 NORM (ABNORM)	ENCUMBERED YEAR-TO-DATE	UNENCUMBERED BALANCE	% BDTG USED
Fund 591 - WATER SYSTEM							
591-000-544.000	STATE GRANT - DWAM	103,228.00	0.00	0.00	0.00	103,228.00	0.00
591-000-628.000	WATER OMR FEES	320,678.00	27,337.13	80,775.60	0.00	239,902.40	25.19
591-000-629.000	WATER USAGE FEES PER 1000 GALLONS	387,139.00	25,871.40	25,451.82	0.00	361,687.18	6.57
591-000-636.000	CONNECTIONS	1,000.00	0.00	0.00	0.00	1,000.00	0.00
591-000-646.000	BULK WATER SALES REVENUE	2,200.00	76.00	231.00	0.00	1,969.00	10.50
591-000-662.000	SERVICE PENALTIES	11,500.00	852.57	2,220.44	0.00	9,279.56	19.31
591-000-664.000	INTEREST & DIVIDENDS	15,500.00	4,778.76	6,306.28	0.00	9,193.72	40.69
591-000-665.000	BUILDING LEASE REVENUES	53,024.00	0.00	0.00	0.00	53,024.00	0.00
591-000-671.000	MISC. REIMBURSEMENTS	6,900.00	0.00	25.00	0.00	6,875.00	0.36
Fund 591 - WATER SYSTEM:		901,169.00	58,915.86	115,010.14	0.00	786,158.86	12.76
TOTAL REVENUES							

EXPENDITURE REPORT

PERIOD ENDING 03/31/2024
 % Fiscal Year Completed: 24.86

GL NUMBER	DESCRIPTION	2024 AMENDED BUDGET	ACTIVITY FOR MONTH 03/31/24 INCR (DECR)	YTD BALANCE 03/31/2024 NORM (ABNORM)	ENCUMBERED YEAR-TO-DATE	UNENCUMBERED BALANCE	% BDGT USED
Fund 591 - WATER SYSTEM							
001 - ADMINISTRATION		213,788.00	11,461.58	32,074.30	0.00	181,713.70	15.00
002 - TREATMENT AND PUMPING		253,804.00	24,396.76	30,971.63	4,058.00	218,774.37	13.80
003 - COLLECTIONS		152,446.00	5,625.79	15,144.08	0.00	137,301.92	9.93
004 - MAINTENANCE		21,916.00	971.29	986.05	0.00	20,929.95	4.50
011 - DWAM GRANT		103,228.00	452.81	452.81	0.00	102,775.19	0.44
<hr/>							
Fund 591 - WATER SYSTEM:		745,182.00	42,908.23	79,628.87	4,058.00	661,495.13	11.23
TOTAL EXPENDITURES							

GL NUMBER	DESCRIPTION	2024 AMENDED BUDGET	MONTH 03/31/24 ACTIVITY FOR INCR (DECR)	YTD BALANCE 03/31/2024 (NORM (ABNORM))	ENCUMBERED YEAR-TO-DATE	UNENCUMBERED BALANCE	% BDTG USED
Fund 651 - MOTOR VEHICLE & EQUIPMENT							
651-000-654.000	DPW CONTRACTING REVENUES	1,545.00	0.00	0.00	0.00	1,545.00	0.00
651-000-664.000	INTEREST & DIVIDENDS	10,000.00	4,385.81	5,790.26	0.00	4,209.74	57.90
651-000-670.000	INTERDEPARTMENT RENTALS	435,720.00	21,158.41	85,947.87	0.00	349,772.13	19.73
651-000-671.000	MISC REIMBURSEMENTS	400.00	0.00	0.00	0.00	400.00	0.00
651-000-673.000	SALE OF ASSETS	12,000.00	0.00	0.00	0.00	12,000.00	0.00
651-000-699.000	TRANSFER FROM FUND BALANCE	91,000.00	0.00	0.00	0.00	91,000.00	0.00

Fund 651 - MOTOR VEHICLE & EQUIPMENT:

TOTAL REVENUES	550,665.00	25,544.22	91,738.13	0.00	458,926.87	16.66
----------------	------------	-----------	-----------	------	------------	-------

TOTAL REVENUES - ALL FUNDS

5,764,477.00	233,975.67	539,057.31	0.00	5,225,419.69	9.35
--------------	------------	------------	------	--------------	------

GL NUMBER	DESCRIPTION	2024 AMENDED BUDGET	ACTIVITY FOR MONTH 03/31/24 INCR (DECR)	YTD BALANCE 03/31/2024 NORM (ABNORM)	ENCUMBERED YEAR-TO-DATE	UNENCUMBERED BALANCE	% BDGT USED
Fund 651 - MOTOR VEHICLE & EQUIPMENT							
001 - ADMINISTRATION		550,386.00	20,483.40	44,108.80	50,892.58	455,384.62	17.26
<hr/>							
Fund 651 - MOTOR VEHICLE & EQUIPMENT:							
TOTAL EXPENDITURES		550,386.00	20,483.40	44,108.80	50,892.58	455,384.62	17.26
<hr/>							
TOTAL EXPENDITURES - ALL FUNDS		5,606,378.00	358,861.73	1,049,703.55	357,959.12	4,198,715.33	25.11

GL NUMBER	DESCRIPTION	2024 AMENDED BUDGET	ACTIVITY FOR MONTH 03/31/24 INCR (DECR)	YTD BALANCE 03/31/2024 NORM (ABNORM)	ENCUMBERED YEAR-TO-DATE	UNENCUMBERED BALANCE	% BGDGT USED
Fund 101 - GENERAL FUND							
Fund 101 - GENERAL FUND:							
TOTAL REVENUES		2,032,184.00	37,452.66	54,753.93	0.00	1,977,430.07	2.69
TOTAL EXPENDITURES		2,032,184.00	130,601.82	420,915.23	7,201.89	1,604,066.88	21.07
NET OF REVENUES & EXPENDITURES		0.00	(93,149.16)	(366,161.30)	(7,201.89)	373,363.19	100.00
Fund 202 - MAJOR STREET							
Fund 202 - MAJOR STREET:							
TOTAL REVENUES		547,966.00	25,079.96	25,543.83	0.00	522,422.17	4.66
TOTAL EXPENDITURES		547,966.00	6,548.74	48,863.44	116,257.21	382,845.35	30.13
NET OF REVENUES & EXPENDITURES		0.00	18,531.22	(23,319.61)	(116,257.21)	139,576.82	100.00
Fund 203 - LOCAL STREET							
Fund 203 - LOCAL STREET:							
TOTAL REVENUES		505,198.00	11,531.85	12,239.44	0.00	492,958.56	2.42
TOTAL EXPENDITURES		503,823.00	27,697.60	75,163.90	77,251.01	351,408.09	30.25
NET OF REVENUES & EXPENDITURES		1,375.00	(16,165.75)	(62,924.46)	(77,251.01)	141,550.47	10,194.5
Fund 244 - ECONOMIC DEVELOPMENT							
Fund 244 - ECONOMIC DEVELOPMENT:							
TOTAL REVENUES		17,600.00	0.42	1.72	0.00	17,598.28	0.01
TOTAL EXPENDITURES		17,600.00	1,125.18	8,375.54	0.00	9,224.46	47.59
NET OF REVENUES & EXPENDITURES		0.00	(1,124.76)	(8,373.82)	0.00	8,373.82	100.00
Fund 401 - CAPITAL PROJECTS: SEEGER STREET PROJECT							
Fund 401 - CAPITAL PROJECTS: SEEGER STREET PROJECT:							
TOTAL REVENUES		37,494.00	2,920.54	3,812.81	0.00	33,681.19	10.17
TOTAL EXPENDITURES		37,494.00	4,491.82	13,354.91	0.00	24,139.09	35.62
NET OF REVENUES & EXPENDITURES		0.00	(1,571.28)	(9,542.10)	0.00	9,542.10	100.00
Fund 408 - WATER RECREATION FUND							
Fund 408 - WATER RECREATION FUND:							
TOTAL REVENUES		500.00	0.00	0.00	0.00	(90,000.00)	100.00
TOTAL EXPENDITURES		500.00	0.00	0.00	0.00	(90,150.40)	100.00
NET OF REVENUES & EXPENDITURES		0.00	0.00	(150.40)	0.00	150.40	100.00
Fund 590 - WASTEWATER TREATMENT							
Fund 590 - WASTEWATER TREATMENT:							
TOTAL REVENUES		1,171,701.00	72,530.16	145,957.31	0.00	1,025,743.69	12.46
TOTAL EXPENDITURES		1,171,243.00	125,004.94	269,142.46	102,298.43	799,802.11	31.71
NET OF REVENUES & EXPENDITURES		458.00	(52,474.78)	(123,185.15)	(102,298.43)	225,941.58	49,232.2
Fund 591 - WATER SYSTEM							
Fund 591 - WATER SYSTEM:							
TOTAL REVENUES		901,169.00	58,915.86	115,010.14	0.00	786,158.86	12.76
TOTAL EXPENDITURES		745,182.00	42,908.23	79,628.87	4,058.00	661,495.13	11.23
NET OF REVENUES & EXPENDITURES		155,987.00	16,007.63	35,381.27	(4,058.00)	124,663.73	20.08

GL NUMBER	DESCRIPTION	2024 AMENDED BUDGET	ACTIVITY FOR		YTD BALANCE 03/31/2024 NORM (ABNORM)	ENCUMBERED YEAR-TO-DATE	UNENCUMBERED BALANCE	% BDDT USED
			MONTH 03/31/24 INCR (DECR)	MONTH 03/31/24 INCR (DECR)				
	Fund 651 - MOTOR VEHICLE & EQUIPMENT							
	Fund 651 - MOTOR VEHICLE & EQUIPMENT:							
	TOTAL REVENUES	550,665.00	25,544.22	91,738.13	0.00	458,926.87	16.66	
	TOTAL EXPENDITURES	550,386.00	20,483.40	44,108.80	50,892.58	455,384.62	17.26	
	NET OF REVENUES & EXPENDITURES	279.00	5,060.82	47,629.33	(50,892.58)	3,542.25	1,169.62	
	TOTAL REVENUES - ALL FUNDS	5,764,477.00	233,975.67	539,057.31	0.00	5,225,419.69	9.35	
	TOTAL EXPENDITURES - ALL FUNDS	5,606,378.00	358,861.73	1,049,703.55	357,959.12	4,198,715.33	25.11	
	NET OF REVENUES & EXPENDITURES	158,099.00	(124,886.06)	(510,646.24)	(357,959.12)	1,026,704.36		



Moving Forward Working Together

To: Village President and Council

From: Nanette Walsh, Clerk/Treasurer

Date: April 29, 2024

**RE: First Quarter, 2024 Amendment to the Village of Cass City
2024 Financial Budget**

Every three months, it is appropriate to analyze and amend our budget. After review of the First Quarter 2024 Financial reports, a budget amendment is presented, focusing on:

General Fund (101)

- Recognize additional Dog Park Donations
- Correct Clerk Staff Fringes
- Correct Copier Lease Expense per new GASB requirements
- Increase Transfer to EDC amount for Hillaker Loan/Legal
- Realign expenses to current activity

Major Streets (202)

- No changes

Local Streets (203)

- Recognize additional Bridge Tax Revenues

Economic Development Corporation (244)

- Recognize additional Transfer to EDC amount for Hillaker Loan/Legal
- Realign expenses to current activity

Downtown Development Authority (248)

- Increase utilization of Fund Balance for Business Builders Project
- Realign expenses to current activity
- Increase fund balance utilization to cover increased costs

WWTP (590)

- No changes

Water (591)

- Recognize increased interest revenue
- Realign expenses to current activity

MVF (651)

- No changes

Therefore, we request the following:

MOTION: Approve First Quarter 2024 Amendment of the 2024 Village of Cass City Financial Budget.

3/31/2024

VILLAGE OF CASS CITY
FIRST QUARTER 2024 BUDGET AMENDMENT I
 FOR THE PERIOD ENDING 3/31/2024

FUND: GENERAL FUND		Original	YTD BALANCE	ADD OR SUBTRACT	2024 FIRST QTR
GL NUMBER	DESCRIPTION	BUDGET	4/26/2024	FROM BUDGET	AMENDED BUDGET
Fund 101 - GENERAL FUND					
101-000-402.000	REAL PROPERTY TAXES	648,874.00	0.00		648,874.00
101-000-403.000	REAL PROPERTY TAX - LANDFILL	0.00	0.00		0.00
101-000-404.000	REAL PROPERTY TX-PA359 (PROMOTIONS)	36,360.00	0.00		36,360.00
101-000-410.000	PERSONAL PROPERTY TAXES	58,070.00	0.00		58,070.00
101-000-410.100	LOCAL COMM STABILIZATION PPT REIMBURSE	0.00	0.00		0.00
101-000-417.000	PERSONAL PROP TAX - LANDFILL	0.00	0.00		0.00
101-000-418.000	PER PROP TAX-PA 359 (PROMOTIONS)	3,182.00	0.00		3,182.00
101-000-420.000	DELINQUENT PERSONAL TAX COLLECTIONS	0.00	0.00		0.00
101-000-441.100	PPT LOCAL STABILIZATION FUNDS	0.00	0.00		0.00
101-000-445.000	PENALTIES & INTEREST TAXES	150.00	0.00		150.00
101-000-447.000	COLLECTION FEES TAXES	10,586.00	0.00		10,586.00
101-000-451.000	LIQUOR LICENSE FEES	2,000.00	0.00		2,000.00
101-000-501.000	FEDERAL GRANT	0.00	0.00		0.00
101-000-528.000	OTHER FEDERAL GRANTS - CARES ACT	0.00	0.00		0.00
101-000-528.100	OTHER FEDERAL, CARES ACT, PSPHPR	0.00	0.00		0.00
101-000-543.000	STATE GRANT-PA 302 FUNDS	927.00	0.00		927.00
101-000-544.000	STATE GRANT - RRC	0.00	0.00		0.00
101-000-573.000	LOCAL COMM STABILIZATION SHARE (LCAS)	200,058.00	0.00		200,058.00
101-000-574.000	STATE SHARED REVENUE	316,140.00	0.00		316,140.00
101-000-575.000	STATE SHARED REV, EVIP	59,414.00	0.00		59,414.00
101-000-580.000	CONTRIBUTIONS FROM TUSCOLA COUNTY	0.00	0.00		0.00
101-000-581.000	REVENUES, CCPs: SCHOOL.RESOURCE.OFFICER	68,000.00	25,250.40		68,000.00
101-000-582.000	YOUTH ASSISTANCE GRANTS	0.00	0.00		0.00
101-000-584.000	RESTITUTION FUNDS, CCPD	100.00	0.00		100.00
101-000-585.000	OTHER GRANTS, CCPD	0.00	0.00		0.00
101-000-607.000	CABLE FRANCHISE FEES	36,050.00	0.00		36,050.00
101-000-608.000	ZONING PERMIT FEES	5,000.00	215.00		5,000.00
101-000-609.000	RENTAL REGISTRATION FEES	1,000.00	0.00		1,000.00
101-000-625.000	MISCELLANEOUS REVENUES	2,600.00	411.00		2,600.00
101-000-626.000	MEDICAL MARIJUANA ANNUAL PERMIT FEE	0.00	0.00		0.00
101-000-640.000	REFUSE FEES	170,959.00	39,127.89		170,959.00
101-000-650.000	SWIM SHOP REVENUES	0.00	0.00		0.00
101-000-651.000	SWIMMING FEES	60,000.00	3,065.00		60,000.00
101-000-652.000	ARTS / CRAFTS FEES	10,000.00	1,600.00		10,000.00
101-000-653.000	OTHER RECREATION FEES	2,800.00	705.00		2,800.00
101-000-654.000	P & R CONTRACTING REVENUES	0.00	0.00		0.00
101-000-655.000	ORDINANCE FINES	1,500.00	1,086.05		1,500.00
101-000-662.000	REFUSE PENALTIES	3,500.00	918.93		3,500.00
101-000-663.000	GF, INSURANCE PROCEEDS	0.00	0.00		0.00
101-000-664.000	INTEREST & DIVIDENDS	18,000.00	2,082.79		18,000.00
101-000-671.000	MISCELLANEOUS REIMBURSEMENT	4,500.00	829.09		4,500.00
101-000-673.000	SALE OF ASSETS, SPRING AUCTION	0.00	0.00		0.00
101-000-674.000	POOL DONATIONS/SPONSORSHIPS	250.00	0.00		250.00
101-000-675.000	DONATIONS FROM PUBLIC & PRIVATE	11,000.00	2,989.17		11,000.00
101-000-676.000	DOG PARK DONATIONS	0.00	141.00	200.00	200.00
101-000-678.000	DONATIONS, MUSIC IN THE PARK	2,500.00	800.00		2,500.00
101-000-679.000	REVENUES, DTE ESCROW	0.00	0.00		0.00
101-000-694.000	OVER/SHORT CASH	0.00	0.00		0.00
101-000-699.000	TRANSFERS IN, ADMIN CHRG	203,664.00	0.00		203,664.00
101-000-699.100	TRANSFER IN FROM FUND BALANCE	85,000.00	0.00		85,000.00
101-000-699.200	TRANSFER IN FROM FB, POLICE	0.00	0.00		0.00
101-000-699.300	TRANSFER IN FROM FB, COMM PROMO	7,500.00	0.00		7,500.00
101-000-699.400	TRANSFER IN FROM FB, DOG PARK.	2,500.00	0.00		2,500.00
Total General Fund Revenues		2,032,184.00	79,221.32	200.00	2,032,384.00

GL NUMBER	DESCRIPTION	Original BUDGET	YTD BALANCE 4/26/2024	ADD OR SUBTRACT FROM BUDGET	2024 FIRST QTR AMENDED BUDGET
Dept 101 - COUNCIL					
101-101-703.000	COUNCIL SALARIES	3,500.00	0.00		3,500.00
101-101-740.000	SUPPLIES	500.00	0.00		500.00
101-101-807.000	MEMBERSHIP/DUES	0.00	0.00		0.00
101-101-860.000	TRAVEL/MEALS/LODGING	1,200.00	0.00		1,200.00
101-101-960.000	PROFESSIONAL DEVELOPMENT	2,500.00	136.71		2,500.00
Total Dept 101 - COUNCIL		7,700.00	136.71	-	7,700.00
Dept 172 - ADMINISTRATIVE					
101-172-706.000	SALARIES & WAGES	97,753.00	30,077.89		97,753.00
101-172-714.000	FRINGE BENEFITS	31,590.00	9,303.71		31,590.00
101-172-715.000	FICA/MEDICARE	7,702.00	2,408.22		7,702.00
101-172-722.000	RETIREMENT	9,775.00	3,007.84		9,775.00
101-172-726.000	CAR/VEHICLE ALLOWANCE	4,200.00	1,400.00		4,200.00
101-172-740.000	SUPPLIES	1,730.00	197.98		1,730.00
101-172-800.000	ADMINISTRATION CONTRACTED SERVICES	0.00	0.00		0.00
101-172-807.000	MEMBERSHIPS & DUES	1,751.00	425.00		1,751.00
101-172-853.000	COMMUNICATIONS/DIGITAL	2,348.00	892.44		2,348.00
101-172-860.000	TRAVEL/MEALS/LODGING	2,575.00	316.17		2,575.00
101-172-874.000	RETIREE'S FRINGE BENEFITS	4,296.00	913.50		4,296.00
101-172-943.000	EQUIPMENT RENTAL	0.00	0.00		0.00
101-172-960.000	PROFESSIONAL DEVELOPMENT	3,296.00	275.00		3,296.00
101-172-977.000	EQUIPMENT, UNDER \$5,000	1,545.00	784.51		1,545.00
Total Dept 172 - ADMINISTRATIVE		168,561.00	50,002.26	-	168,561.00
Dept 215 - CLERK STAFF					
101-215-706.000	SALARIES & WAGES	113,309.00	29,016.75		113,309.00
101-215-707.000	SALARIES & WAGES - PART-TIME	20,278.00	5,609.39		20,278.00
101-215-714.000	FRINGE BENEFITS	59,960.00	12,550.15	(22,000.00)	37,960.00
101-215-715.000	FICA/MEDICARE	7,894.00	2,652.95		7,894.00
101-215-722.000	RETIREMENT	9,910.00	2,877.59		9,910.00
101-215-853.000	COMMUNICATIONS	1,483.00	160.00		1,483.00
101-215-860.000	TRAVEL/MEALS/LODGING	2,060.00	20.10		2,060.00
101-215-960.000	CLERK STAFF PROFESSIONAL DEV.	2,575.00	582.12		2,575.00
101-215-977.000	EQUIPMENT UNDER \$5000	1,030.00	0.00		1,030.00
Total Dept 215 - CLERK STAFF		218,499.00	53,469.05	(22,000.00)	196,499.00
Dept 223 - FINANCE					
101-223-807.000	AUDIT FEES	15,965.00	0.00		15,965.00
101-223-808.000	CPA SERVICES	5,150.00	0.00		5,150.00
101-223-809.000	FINANCIAL SOFTWARE/SUPPORT	0.00	0.00		0.00
Total Dept 223 - FINANCE		21,115.00	0.00	-	21,115.00
Dept 261 - GENERAL GOVERNMENT					
101-261-740.000	SUPPLIES	7,004.00	1,356.78		7,004.00
101-261-741.000	POSTAGE	11,330.00	3,648.24		11,330.00
101-261-807.000	MEMBERSHIPS/DUES	2,987.00	1,072.50		2,987.00
101-261-826.000	LEGAL FEES	38,110.00	8,715.00		38,110.00
101-261-827.000	INSURANCE & BONDS	15,450.00	0.00		15,450.00
101-261-853.000	TELEPHONE	5,034.00	1,991.89		5,034.00
101-261-900.000	PRINTING & PUBLISHING	6,180.00	108.00		6,180.00
101-261-933.000	MAINTENANCE CONTRACTS EQUIPMENT	39,331.00	8,614.98	(4,740.00)	34,591.00
101-261-956.000	MISC EXPENSE BANK/PENSION CHG	2,575.00	350.71		2,575.00
101-261-965.000	TAXES ABATED	788.00	0.00		788.00
101-261-969.000	BAD DEBT EXPENSE	0.00	0.00		0.00
101-261-970.000	CAPITAL OUTLAY	0.00	0.00		0.00
101-261-970.100	CAPITAL OUTLAY, GIS SYSTEM	0.00	0.00		0.00
101-261-977.000	EQUIPMENT UNDER \$ 5K	1,030.00	0.00		1,030.00
101-261-991.000	EQUIPMENT LEASE, INTEREST (Copier)	0.00	0.00	1,471.00	1,471.00
101-261-996.00	EQUIPMENT LEASE, Principal (Copier)	0.00	0.00	3,269.00	3,269.00
Total Dept 261 - GENERAL GOVERNMENT		129,819.00	25,858.10	-	129,819.00
Dept 262 - ELECTIONS					
101-262-703.000	ELECTION SALARIES	103.00	0.00		103.00
101-262-900.000	ELECTION PRINTING	0.00	0.00		0.00
Total Dept 262 - ELECTIONS		103.00	0.00	-	103.00

GL NUMBER	DESCRIPTION	Original BUDGET	YTD BALANCE 4/26/2024	ADD OR SUBTRACT FROM BUDGET	2024 FIRST QTR AMENDED BUDGET
Dept 265 - BUILDINGS & GROUNDS					
101-265-706.000	SALARIES & WAGES	2,575.00	381.53		2,575.00
101-265-707.000	SALARIES & WAGES - PART-TIME	16,796.00	4,904.65		16,796.00
101-265-714.000	FRINGE BENFITS	2,575.00	406.38		2,575.00
101-265-715.000	FICA/MEDICARE	1,127.00	384.07		1,127.00
101-265-722.000	RETIREMENT	438.00	38.16		438.00
101-265-740.000	SUPPLIES	2,068.00	176.12		2,068.00
101-265-800.000	CONTRACTED SERVICES	3,300.00	1,273.10		3,300.00
101-265-920.000	UTILITIES	6,450.00	1,870.75		6,450.00
101-265-933.000	REPAIR AND MAINTENANCE	2,250.00	0.00		2,250.00
101-265-943.000	EQUIPMENT RENTAL	675.00	0.00		675.00
101-265-970.000	CAPITAL OUTLAY	0.00	0.00		0.00
Total Dept 265 - BUILDINGS & GROUNDS		38,254.00	9,434.76	-	38,254.00
Dept 291 - COMMUNITY PROMOTION (PA 359)					
101-291-706.000	SALARIES & WAGES	9,435.00	2,745.32		9,435.00
101-291-707.000	SALARIES & WAGES - PART-TIME	3,240.00	179.89		3,240.00
101-291-714.000	FRINGE BENFITS	1,996.00	965.91		1,996.00
101-291-715.000	FICA/MEDICARE	1,226.00	220.93		1,226.00
101-291-722.000	RETIREMENT	941.00	264.88		941.00
101-291-740.000	OPERATING SUPPLIES	3,450.00	4,086.78	1,500.00	4,950.00
101-291-741.000	POSTAGE	0.00	0.00		0.00
101-291-800.000	CONTRACTED SERVICES	12,710.00	261.06		12,710.00
101-291-807.000	MEMBERSHIPS & DUES	130.00	151.00	300.00	430.00
101-291-853.000	TELEPHONE EXPENSE	0.00	0.00		0.00
101-291-880.000	COMMUNITY PROMOTION	6,200.00	0.00		6,200.00
101-291-881.000	MARKETING/STRATEGIC PLANNING	0.00	0.00		0.00
101-291-900.000	PRINTING AND PUBLISHING	2,500.00	0.00		2,500.00
101-291-943.000	EQUIPMENT RENTAL	4,500.00	1,799.18		4,500.00
101-291-960.000	PROFESSIONAL DEVELOPMENT	0.00	0.00		0.00
101-291-965.000	TUSCOLA COUNTY EDC	7,500.00	7,500.00		7,500.00
101-291-970.000	CAPITAL OUTLAY	0.00	0.00		0.00
101-291-977.000	EQUIPMENT UNDER 5K	0.00	0.00		0.00
Total Dept 291 - COMMUNITY PROMOTION (PA 359)		53,828.00	18,174.95	1,800.00	55,628.00
Dept 301 - POLICE DEPARTMENT					
101-301-706.000	SALARIES & WAGES	277,561.00	93,983.00		277,561.00
101-301-707.000	SALARIES & WAGES - PART-TIME	78,534.00	21,217.61		78,534.00
101-301-708.000	SALARIES, S.R.O.	43,689.00	14,089.04		43,689.00
101-301-714.000	FRINGE BENFITS	120,540.00	38,527.28		120,540.00
101-301-715.000	FICA/MEDICARE	31,698.00	9,862.44		31,698.00
101-301-722.000	RETIREMENT	31,185.00	9,539.13		31,185.00
101-301-740.000	OPERATING SUPPLIES	2,060.00	643.74		2,060.00
101-301-768.000	UNIFORMS	5,000.00	0.00		5,000.00
101-301-800.000	ADMINISTRATION CONTRACTED SERVICES	1,000.00	1,963.40	1,000.00	2,000.00
101-301-807.000	MEMBERSHIP & DEVELOPMENT	300.00	145.00		300.00
101-301-827.000	INSURANCE & BONDS	0.00	0.00		0.00
101-301-851.000	RADIO MAINTENANCE	250.00	0.00		250.00
101-301-853.000	COMMUNICATIONS	11,485.00	6,344.44		11,485.00
101-301-860.000	TRAVEL/MEALS/LODGING	1,500.00	900.86		1,500.00
101-301-933.000	EQUIPMENT MAINTENANCE	1,030.00	0.00		1,030.00
101-301-943.000	EQUIPMENT RENTAL POLICE	69,420.00	17,355.00		69,420.00
101-301-956.000	GRANT EXPENSES, OTHER EXPENSES	0.00	0.00		0.00
101-301-957.000	EQUIPMENT EXPENSE, CCPD SEIZED FUND	0.00	0.00		0.00
101-301-960.000	PROFESSIONAL DEVELOPMENT	3,000.00	2,272.55		3,000.00
101-301-960.100	PA 302 TRAINING FUND	900.00	0.00		900.00
101-301-970.000	CAPITAL OUTLAY	0.00	0.00		0.00
101-301-977.000	EQUIPMENT UNDER \$5000	3,000.00	3,180.60	500.00	3,500.00
Total Dept 301 - POLICE DEPARTMENT		682,152.00	220,024.09	1,500.00	683,652.00
Dept 315 - CRIME & SAFETY					
101-315-701.000	CROSSING GUARDS	11,000.00	0.00		11,000.00
Total Dept 315 - CRIME & SAFETY		11,000.00	0.00	-	11,000.00

GL NUMBER	DESCRIPTION	Original BUDGET	YTD BALANCE 4/26/2024	ADD OR SUBTRACT FROM BUDGET	2024 FIRST QTR AMENDED BUDGET
Dept 440 - MISC GOVERNMENT					
101-440-965.000	TRANSFER TO OTHERS (DDA/EDC)	13,500.00	0.00	4,500.00	18,000.00
Total Dept 440 - MISC GOVERNMENT		13,500.00	0.00	4,500.00	18,000.00
Dept 441 - PUBLIC WORKS					
101-441-706.000	SALARIES & WAGES	2,559.00	0.00		2,559.00
101-441-707.000	SALARIES & WAGES - PART-TIME	2,025.00	0.00		2,025.00
101-441-714.000	FRINGE BENFITS	1,064.00	10.95		1,064.00
101-441-715.000	FICA/MEDICARE	307.00	0.00		307.00
101-441-722.000	RETIREMENT	269.00	0.00		269.00
101-441-740.000	SUPPLIES	4,499.00	109.79		4,499.00
101-441-800.000	CONTRACTED SERVICES	8,164.00	0.00		8,164.00
101-441-802.000	VACANT LOT CLEARANCE	0.00	0.00		0.00
101-441-926.000	STREET LIGHTING	0.00	0.00		0.00
101-441-943.000	EQUIPMENT RENTAL	2,800.00	0.00		2,800.00
101-441-945.000	BUILDING LEASE FEE	2,524.00	0.00		2,524.00
101-441-960.000	PROFESSIONAL DEVELOPMENT	0.00	0.00		0.00
101-441-970.000	CAPITAL OUTLAY	0.00	0.00		0.00
Total Dept 441 - PUBLIC WORKS		24,211.00	120.74	-	24,211.00
Dept 520 - SOLID WASTE DISPOSAL					
101-520-706.000	SALARIES & WAGES	0.00	0.00		0.00
101-520-707.000	SALARIES & WAGES - PART-TIME	0.00	0.00		0.00
101-520-714.000	FRINGE BENFITS	0.00	0.00		0.00
101-520-715.000	FICA/MEDICARE	0.00	0.00		0.00
101-520-722.000	RETIREMENT	0.00	0.00		0.00
101-520-740.000	OPERATING SUPPLIES	0.00	0.00		0.00
101-520-800.100	CONTRACTED SERV, LANDFILL MT/ENGINEERING	0.00	0.00		0.00
101-520-801.000	CONTRACTED SERV - REFUSE/RECYC CONTRACT	170,959.00	51,914.72		170,959.00
101-520-802.000	TESTING LANDFILL, WWTP LAB SERV	0.00	0.00		0.00
101-520-943.000	EQUIPMENT RENTAL	0.00	0.00		0.00
Total Dept 520 - SOLID WASTE DISPOSAL		170,959.00	51,914.72	-	170,959.00
Dept 722 - PLANNING AND ZONING					
101-722-706.000	SALARIES & WAGES	42,313.00	12,256.06		42,313.00
101-722-707.000	SALARIES & WAGES - PART-TIME	3,090.00	4,822.00	9,000.00	12,090.00
101-722-714.000	FRINGE BENFITS	3,702.00	283.57	900.00	4,602.00
101-722-715.000	FICA/MEDICARE	3,267.00	1,306.46		3,267.00
101-722-722.000	RETIREMENT	4,656.00	1,260.90		4,656.00
101-722-740.000	SUPPLIES	450.00	25.42		450.00
101-722-800.000	CONTRACTED SERVICES	3,000.00	0.00		3,000.00
101-722-801.000	CONTRACTUAL, RENTAL INSPECTIONS	0.00	0.00		0.00
101-722-807.000	MEMBERSHIP & DUES	225.00	0.00		225.00
101-722-960.000	PROFESSIONAL DEVELOPMENT	1,000.00	0.00		1,000.00
Total Dept 722 - PLANNING AND ZONING		61,703.00	19,954.41	9,900.00	71,603.00
Dept 752 - SWIMMING POOL					
101-752-706.000	SALARIES & WAGES	6,996.00	512.89		6,996.00
101-752-707.000	SALARIES & WAGES - PART-TIME	64,075.00	0.00		64,075.00
101-752-714.000	FRINGE BENFITS	22,266.00	150.21		22,266.00
101-752-715.000	FICA/MEDICARE	4,843.00	38.55		4,843.00
101-752-722.000	RETIREMENT	734.00	51.69		734.00
101-752-740.000	OPERATING SUPPLIES	7,500.00	31.02		7,500.00
101-752-743.000	CHEMICALS	22,000.00	0.00		22,000.00
101-752-800.000	CONTRACTED SERVICES	2,400.00	131.00		2,400.00
101-752-827.000	INSURANCE & BONDS	325.00	0.00		325.00
101-752-853.000	TELEPHONE	500.00	92.34		500.00
101-752-900.000	PRINTING & PUBLISHING	550.00	0.00		550.00
101-752-920.000	UTILITIES	17,800.00	90.39		17,800.00
101-752-933.000	REPAIR & MAINTENANCE	5,000.00	0.00		5,000.00
101-752-943.000	EQUIPMENT RENTAL	1,125.00	0.00		1,125.00
101-752-970.000	CAPITAL OUTLAY	6,000.00	0.00		6,000.00
Total Dept 752 - SWIMMING POOL		162,114.00	1,098.09	-	162,114.00

GL NUMBER	DESCRIPTION	Original BUDGET	YTD BALANCE 4/26/2024	ADD OR SUBTRACT FROM BUDGET	2024 FIRST QTR AMENDED BUDGET
Dept 754 - PARKS DEPARTMENT					
101-754-706.000	SALARIES & WAGES	85,531.00	13,034.57		85,531.00
101-754-707.000	SALARIES & WAGES - PART-TIME	41,632.00	2,498.04		41,632.00
101-754-714.000	FRINGE BENFITS	17,736.00	15,831.57		17,736.00
101-754-715.000	FICA/MEDICARE	5,610.00	1,168.43		5,610.00
101-754-722.000	RETIREMENT	4,073.00	1,259.13		4,073.00
101-754-740.000	SUPPLIES	12,301.00	1,471.54		12,301.00
101-754-778.000	EXPENSES, MUSIC IN THE PARK	2,500.00	0.00		2,500.00
101-754-779.000	EXPENSES, DOG PARK	0.00	248.00	500.00	500.00
101-754-800.000	CONTRACTED SERVICES	5,000.00	568.75		5,000.00
101-754-827.000	INSURANCE & BONDS	590.00	0.00		590.00
101-754-853.000	TELEPHONE	1,300.00	360.00		1,300.00
101-754-860.000	TRAVEL/MEALS/LODGING	1,200.00	251.05		1,200.00
101-754-920.000	UTILITIES	5,300.00	2,015.38		5,300.00
101-754-933.000	REPAIR & MAINTENANCE	9,500.00	1,833.99		9,500.00
101-754-943.000	EQUIPMENT RENTAL	33,000.00	3,400.45		33,000.00
101-754-970.000	CAPITAL OUTLAY	24,000.00	20,100.21		24,000.00
101-754-977.000	EQUIPMENT UNDER \$5000	1,500.00	5,038.00	4,000.00	5,500.00
Total Dept 754 - PARKS DEPARTMENT		250,773.00	69,079.11	4,500.00	255,273.00

GL NUMBER	DESCRIPTION	Original BUDGET	YTD BALANCE 4/26/2024	ADD OR SUBTRACT FROM BUDGET	2024 FIRST QTR AMENDED BUDGET
Dept 758 - RECREATION / DAYCAMP					
101-758-706.000	SALARIES & WAGES	225.00	109.72		225.00
101-758-707.000	SALARIES & WAGES - PART-TIME	11,735.00	0.00		11,735.00
101-758-714.000	FRINGE BENFITS	350.00	0.00		350.00
101-758-715.000	FICA/MEDICARE	1,000.00	8.37		1,000.00
101-758-722.000	RETIREMENT	55.00	10.98		55.00
101-758-740.000	OTHER RECREATION SUPPLIES	0.00	0.00		0.00
101-758-741.000	ARTS AND CRAFTS SUPPLIES	800.00	0.00		800.00
101-758-741.100	DAY CAMP SUPPLIES, FIELD TRIPS	2,300.00	0.00		2,300.00
101-758-827.000	INSURANCE & BONDS	0.00	0.00		0.00
101-758-853.000	COMMUNICATIONS	428.00	101.28		428.00
101-758-970.000	CAPITAL OUTLAY	0.00	0.00		0.00
101-758-977.000	EQUIPMENT, UNDER 5K	1,000.00	285.00		1,000.00
Total Dept 758 - RECREATION DEPARTMENT		17,893.00	515.35	-	17,893.00

TOTAL EXPENDITURES		2,032,184.00	519,782.34	200.00	2,032,384.00
Fund 101 - GENERAL FUND:					
TOTAL REVENUES		2,032,184.00	79,221.32	200.00	2,032,384.00
TOTAL EXPENDITURES		2,032,184.00	519,782.34	200.00	2,032,384.00
NET OF REVENUES & EXPENDITURES		0.00	(440,561.02)	-	0.00

FUND: MAJOR STREETS		Original	YTD BALANCE	ADD OR SUBTRACT	2024 FIRST QTR
GL NUMBER	DESCRIPTION	BUDGET	4/26/2024	FROM BUDGET	AMENDED BUDGET
Fund 202 - MAJOR STREET					
202-000-402.000	MJ ST REAL PROPERTY TAXES	27,398.00	0.00		27,398.00
202-000-410.000	MJ ST PERSONAL PROPERTY TAXES	2,300.00	0.00		2,300.00
202-000-420.000	DELINQUENT TAX REVENUE	0.00	0.00		0.00
202-000-441.100	PPT LOCAL STABILIZATION FUNDS	0.00	0.00		0.00
202-000-546.000	FEDERAL PORTION, S. SEEGER ST	0.00	0.00		0.00
202-000-547.000	MDOT PORTION, S. SEEGER ST	0.00	0.00		0.00
202-000-553.000	MJ ST GAS & WEIGHT	284,485.00	49,874.39		284,485.00
202-000-573.000	LOCAL COMM STABILIZATION SHARE (LCAS)	7,088.00	0.00		7,088.00
202-000-607.000	PA 48 METRO ACT, TELECOM RT OF WAY	14,075.00	0.00		14,075.00
202-000-664.000	INTEREST & DIVIDENDS	7,000.00	2,338.01		7,000.00
202-000-671.000	MJ ST MISC. REIMBURSEMENT	6,700.00	0.00		6,700.00
202-000-676.000	TRUNK LINE MAINTENANCE CONTRACT	49,592.00	0.00		49,592.00
202-000-690.000	MJ ST 1.5 MILLS CO. BRIDGE TAX	32,328.00	32,328.00		32,328.00
202-000-691.000	APPROPRIATION FROM GENERAL FUND	117,000.00	0.00		117,000.00
202-000-699.000	APPROP FROM FUND BALANCE	0.00	0.00		0.00
TOTAL Revenues - Major Street		547,966.00	84,540.40	-	547,966.00

Expenditures		Original	YTD BALANCE	ADD OR SUBTRACT	2024 FIRST QTR
Dept 463 - STREET MAINT	DESCRIPTION	BUDGET	4/26/2024	FROM BUDGET	AMENDED BUDGET
202-463-706.000	SALARIES & WAGES	18,603.00	3,532.24		18,603.00
202-463-707.000	SALARIES & WAGES - PART-TIME	1,125.00	511.67		1,125.00
202-463-714.000	FRINGE BENEFITS	6,602.00	1,209.26		6,602.00
202-463-715.000	FICA/MEDICARE	1,402.00	308.49		1,402.00
202-463-722.000	RETIREMENT	1,923.00	358.02		1,923.00
202-463-740.000	SUPPLIES	2,676.00	339.72		2,676.00
202-463-800.000	CONTRACTED SERVICES	240,000.00	0.00		240,000.00
202-463-827.000	INSURANCE & BONDS	179.00	0.00		179.00
202-463-853.000	TELEPHONE EXPENSE	787.00	237.99		787.00
202-463-933.000	MAINTENANCE CONTRACTS EQUIPMENT	580.00	0.00		580.00
202-463-943.000	EQUIPMENT RENTAL	16,500.00	4,376.98		16,500.00
202-463-963.000	ADMIN. CHARGE G.F.	24,837.00	0.00		24,837.00
202-463-970.100	CAPITAL OUTLAY, GIS SYSTEM	0.00	0.00		0.00
202-463-977.000	EQUIPMENT, LESS THAN \$5000	1,000.00	0.00		1,000.00
Total Dept 463 - STREET MAINTENANCE		316,214.00	10,874.37	-	316,214.00

Dept 470 - R. O. W. MAINTENANCE					
202-470-706.000	SALARIES & WAGES	479.00	0.00		479.00
202-470-714.000	FRINGE BENEFITS	598.00	4.20		598.00
202-470-715.000	FICA/MEDICARE	220.00	0.00		220.00
202-470-722.000	RETIREMENT	170.00	0.00		170.00
202-470-740.000	SUPPLIES, SIDEWALKS	1,082.00	0.00		1,082.00
202-470-800.000	CONTRACTED SERVICES, SIDEWALKS	40,000.00	0.00		40,000.00
202-470-943.000	EQUIPMENT RENTAL	0.00	0.00		0.00
Total Dept 470 - R. O. W. MAINTENANCE		42,549.00	4.20	-	42,549.00

Dept 474 - SIGNS					
202-474-706.000	SALARIES & WAGES	1,082.00	787.96		1,082.00
202-474-714.000	FRINGE BENEFITS	576.00	112.89		576.00
202-474-715.000	FICA/MEDICARE	112.00	60.08		112.00
202-474-722.000	RETIREMENT	132.00	30.32		132.00
202-474-740.000	MJ ST SUPPLIES	2,007.00	92.10		2,007.00
202-474-800.000	CONTRACTED SERVICES	1,125.00	0.00		1,125.00
202-474-943.000	EQUIPMENT RENTAL	2,200.00	684.20		2,200.00
Total Dept 474 - SIGNS		7,234.00	1,767.55	-	7,234.00

Dept 478 - SNOW					
202-478-706.000	SALARIES & WAGES	18,391.00	2,128.06		18,391.00
202-478-707.000	SALARIES & WAGES - PART-TIME	1,968.00	739.04		1,968.00
202-478-714.000	FRINGE BENEFITS	9,640.00	1,240.98		9,640.00
202-478-715.000	FICA/MEDICARE	1,477.00	218.34		1,477.00
202-478-722.000	RETIREMENT	1,930.00	154.38		1,930.00
202-478-740.000	SUPPLIES ICE CONTROL	21,089.00	2,617.87		21,089.00
202-478-943.000	EQUIPMENT RENTAL	45,000.00	7,596.33		45,000.00
Total Dept 478 - SNOW		99,495.00	14,695.00	-	99,495.00

GL NUMBER	DESCRIPTION	Original BUDGET	YTD BALANCE 4/26/2024	ADD OR SUBTRACT FROM BUDGET	2024 FIRST QTR AMENDED BUDGET
Dept 484 - LOCAL STREET					
202-484-999.000	TRANSFERS OUT	0.00	0.00		0.00
Total Dept 484 - LOCAL STREET		0.00	0.00	-	0.00
Dept 486 - TRUNKLINE MAINTENANCE					
202-486-706.000	SALARIES & WAGES	1,666.00	162.58		1,666.00
202-486-715.000	FICA/MEDICARE	0.00	0.00		0.00
202-486-722.000	RETIREMENT	0.00	0.00		0.00
202-486-943.000	EQUIPMENT RENTAL TRUNKLINE	5,000.00	166.24		5,000.00
Total Dept 486 - TRUNKLINE MAINTENANCE		6,666.00	328.82	-	6,666.00
Dept 488 - TRUNKLINE SWEEPING/FLUSHING					
202-488-706.000	SALARIES & WAGES	3,787.00	27.93		3,787.00
202-488-715.000	FICA/MEDICARE	0.00	0.00		0.00
202-488-722.000	RETIREMENT	0.00	0.00		0.00
202-488-943.000	EQUIPMENT RENTAL-TRUNKLINE	8,500.00	385.20		8,500.00
Total Dept 488 - TRUNKLINE SWEEPING/FLUSHING		12,287.00	413.13	-	12,287.00
Dept 493 - STATE MONUMENT PROPERTY T.L.					
202-493-706.000	SALARIES & WAGES	283.00	0.00		283.00
202-493-707.000	SALARIES & WAGES - PART-TIME	338.00	0.00		338.00
202-493-715.000	FICA/MEDICARE	0.00	0.00		0.00
202-493-722.000	RETIREMENT	0.00	0.00		0.00
202-493-943.000	EQUIPMENT RENTAL-TRUNKLINE	650.00	0.00		650.00
Total Dept 493 - STATE MONUMENT PROPERTY T.L.		1,271.00	0.00	-	1,271.00
Dept 494 - TRUNKLINE UTILITIES					
202-494-920.000	UTILITIES-TRUNKLINE	11,827.00	129.04		11,827.00
Total Dept 494 - TRUNKLINE SIGNS		11,827.00	129.04	-	11,827.00
Dept 497 - TRUNKLINE SNOW REMOVAL					
202-497-706.000	SALARIES & WAGES	11,563.00	3,614.11		11,563.00
202-497-707.000	SALARIES & WAGES - PART-TIME	1,434.00	0.00		1,434.00
202-497-715.000	FICA/MEDICARE	0.00	0.00		0.00
202-497-722.000	RETIREMENT	0.00	0.00		0.00
202-497-784.000	ICE CONTROL-TRUNKLINE	6,489.00	3,803.82		6,489.00
202-497-943.000	EQUIPMENT RENTAL-TRUNKLINE	22,500.00	12,143.74		22,500.00
Total Dept 497 - TRUNKLINE SNOW REMOVAL		41,986.00	19,561.67	-	41,986.00
Dept 502 - TRUNKLINE FRINGE BENEFITS					
202-502-966.000	LEAVE & BENEFITS-TRUNKLINE	8,437.00	3,597.00		8,437.00
Total Dept 502 - TRUNKLINE FRINGE BENEFITS		8,437.00	3,597.00	-	8,437.00
TOTAL EXPENDITURES		547,966.00	51,370.78	-	547,966.00
Fund 202 - MAJOR STREET:					
TOTAL REVENUES		547,966.00	84,540.40	-	547,966.00
TOTAL EXPENDITURES		547,966.00	51,370.78	-	547,966.00
NET OF REVENUES & EXPENDITURES		0.00	33,169.62	-	0.00

FUND: LOCAL STREETS		Original	YTD BALANCE	ADD OR SUBTRACT	2024 FIRST QTR
GL NUMBER	DESCRIPTION	BUDGET	4/26/2024	FROM BUDGET	AMENDED BUDGET
Fund 203 - LOCAL STREET					
203-000-402.000	REAL PROPERTY TAXES	236,255.00	0.00		236,255.00
203-000-410.000	PERSONAL PROPERTY TAXES	23,699.00	0.00		23,699.00
203-000-441.100	PPT LOCAL STABILIZATION FUNDS	0.00	0.00		0.00
203-000-553.000	GAS & WEIGHT	112,050.00	19,251.81		112,050.00
203-000-555.000	PA 207 OF 2018 REVENUES	0.00	0.00		0.00
203-000-573.000	LOCAL COMM STABILIZATION SHARE (LCAS)	63,841.00	0.00		63,841.00
203-000-607.000	PA 48 METRO ACT, TELECOM RT OF WAY	0.00	0.00		0.00
203-000-625.000	DELINQUENT TAX REVENUE	0.00	0.00		0.00
203-000-664.000	INTEREST & DIVIDENDS	10,000.00	3,281.85		10,000.00
203-000-671.000	MISC REIMBURSEMENTS	2,621.00	0.00		2,621.00
203-000-690.000	1.5 MILLS CO. BRIDGE TAX	46,732.00	50,356.42	3,625.00	50,357.00
203-000-692.000	CONTRIBUTION FROM MAJOR STREETS	0.00	0.00		0.00
203-000-693.000	TRANSFER FROM GF TO LOCAL STREETS	0.00	0.00		0.00
203-000-699.000	TRANSFER IN, LOCAL STREET FUND BALANCE	10,000.00	0.00		10,000.00
Total Dept 000		505,198.00	72,890.08	3,625.00	508,823.00

Expenditures		Original	YTD BALANCE	ADD OR SUBTRACT	2024 FIRST QTR
Dept 463 - STREET MAINTENANCE	DESCRIPTION	BUDGET	4/26/2024	FROM BUDGET	AMENDED BUDGET
203-463-706.000	SALARIES & WAGES	65,081.00	17,942.37		65,081.00
203-463-707.000	SALARIES & WAGES - PART-TIME	2,185.00	2,814.19	3,625.00	5,810.00
203-463-714.000	FRINGE BENEFITS	31,599.00	9,111.63		31,599.00
203-463-715.000	FICA/MEDICARE	6,811.00	1,583.21		6,811.00
203-463-722.000	RETIREMENT	7,500.00	1,190.97		7,500.00
203-463-740.000	SUPPLIES	3,937.00	594.72		3,937.00
203-463-800.000	CONTRACTED SERVICES	65,000.00	0.00		65,000.00
203-463-827.000	INSURANCE & BONDS	179.00	0.00		179.00
203-463-828.000	FEES AND PERMITS	0.00	0.00		0.00
203-463-853.000	TELEPHONE EXPENSE	590.00	117.99		590.00
203-463-933.000	MAINTENANCE CONTRACTS EQUIPMENT	1,445.00	0.00		1,445.00
203-463-943.000	EQUIPMENT RENTAL	107,000.00	19,844.19		107,000.00
203-463-963.000	ADMIN. CHARGE G.F.	10,496.00	0.00		10,496.00
203-463-970.100	CAPITAL OUTLAY, DTE BCHWOOD LGHTS	0.00	0.00		0.00
203-463-977.000	EQUIPMENT, LESS THAN \$5000	1,000.00	0.00		1,000.00
Total Dept 463 - STREET MAINTENANCE		302,823.00	53,199.27	3,625.00	306,448.00

Dept 470 - R. O. W. MAINTENANCE					
203-470-706.000	SALARIES & WAGES	562.00	0.00		562.00
203-470-714.000	FRINGE BENEFITS	332.00	0.00		332.00
203-470-715.000	FICA/MEDICARE	52.00	0.00		52.00
203-470-722.000	RETIREMENT	52.00	0.00		52.00
203-470-740.000	SUPPLIES	1,125.00	0.00		1,125.00
203-470-800.000	CONTRACTUAL SERVICES, SIDEWALKS	40,000.00	0.00		40,000.00
203-470-943.000	EQUIPMENT RENTAL	0.00	0.00		0.00
Total Dept 470 - R. O. W. MAINTENANCE		42,123.00	0.00	-	42,123.00

Dept 474 - SIGNS					
203-474-706.000	SALARIES & WAGES	1,687.00	0.00		1,687.00
203-474-714.000	FRINGE BENEFITS	1,455.00	0.00		1,455.00
203-474-715.000	FICA/MEDICARE	277.00	0.00		277.00
203-474-722.000	RETIREMENT	364.00	0.00		364.00
203-474-740.000	SUPPLIES	1,000.00	92.10		1,000.00
203-474-800.000	CONTRACTED SERVICES	0.00	0.00		0.00
203-474-943.000	EQUIPMENT RENTAL	2,850.00	0.00		2,850.00
Total Dept 474 - SIGNS		7,633.00	92.10	-	7,633.00

GL NUMBER	DESCRIPTION	Original BUDGET	YTD BALANCE 4/26/2024	ADD OR SUBTRACT FROM BUDGET	2024 FIRST QTR AMENDED BUDGET
Dept 478 - SNOW					
203-478-706.000	SALARIES & WAGES	16,205.00	2,106.10		16,205.00
203-478-707.000	SALARIES & WAGES - PART-TIME	2,262.00	1,139.47		2,262.00
203-478-714.000	FRINGE BENFITS	9,083.00	1,047.52		9,083.00
203-478-715.000	FICA/MEDICARE	1,391.00	247.27		1,391.00
203-478-722.000	RETIREMENT	1,820.00	173.84		1,820.00
203-478-740.000	SUPPLIES ICE CONTROL	7,571.00	2,528.47		7,571.00
203-478-800.000	ADMINISTRATION CONTRACTED SERVICES	0.00	0.00		0.00
203-478-943.000	EQUIPMENT RENTAL	27,000.00	8,350.23		27,000.00
Total Dept 478 - SNOW		65,332.00	15,592.90	-	65,332.00
Dept 494 - TRUNKLINE UTILITIES					
203-494-920.000	UTILITIES	85,912.00	20,114.09		85,912.00
Total Dept 494 - TRUNKLINE SIGNS		85,912.00	20,114.09	-	85,912.00
TOTAL EXPENDITURES		503,823.00	88,998.36	3,625.00	507,448.00
Fund 203 - LOCAL STREET:					
TOTAL REVENUES		505,198.00	72,890.08	3,625.00	508,823.00
TOTAL EXPENDITURES		503,823.00	88,998.36	3,625.00	507,448.00
NET OF REVENUES & EXPENDITURES		1,375.00	(16,108.28)	-	1,375.00

FUND: ECONOMIC DEVELOPMENT CORPORATION		Original	YTD BALANCE	ADD OR SUBTRACT	2024 FIRST QTR
GL NUMBER	DESCRIPTION	BUDGET	4/26/2024	FROM BUDGET	AMENDED BUDGET
Fund 244 - ECONOMIC DEVELOPMENT					
244-000-664.000	INTEREST & DIVIDENDS	300.00	1.72		300.00
244-000-671.000	MISC REVENUES, LAND SALE	0.00	0.00		0.00
244-000-691.000	APPROPRIATION FROM FUND BALANCE	3,800.00	0.00		3,800.00
244-000-692.000	CONTRIBUTION FROM GENERAL FUND	13,500.00	0.00	4,500.00	18,000.00
244-000-698.000	PAYLOAN PROCEEDS, TNB FOR DOERR PROPERTY	0.00	0.00		0.00
Total Dept 000		17,600.00	1.72	4,500.00	22,100.00
Expenditures					
Dept 001 - ADMINISTRATIVE		Original	YTD BALANCE	ADD OR SUBTRACT	2024 FIRST QTR
	DESCRIPTION	BUDGET	4/26/2024	FROM BUDGET	AMENDED BUDGET
244-001-707.000	SALARIES & WAGES - PART-TIME	0.00	0.00		0.00
244-001-714.000	FRINGE BENEFITS	0.00	0.00		0.00
244-001-715.000	FICA/MEDICARE	0.00	0.00		0.00
244-001-722.000	RETIREMENT	0.00	0.00		0.00
244-001-740.000	SUPPLIES	500.00	0.00		500.00
244-001-800.000	CONTRACTED SERVICES	500.00	5,000.00	4,500.00	5,000.00
244-001-801.000	ALL EXPENSES	50.00	0.00	-	50.00
244-001-853.000	TELEPHONE	0.00	0.00		0.00
244-001-960.000	PROFESSIONAL DEVELOPMENT	50.00	0.00		50.00
244-001-970.000	CAPITAL OUTLAY	0.00	0.00		0.00
244-001-991.000	LOAN PAYMENT: PRINCIPAL	11,000.00	2,014.74		11,000.00
244-001-996.000	NOTE PAYMENT: INTEREST EXP	5,500.00	1,360.80		5,500.00
Total Dept 001 - ADMINISTRATION		17,600.00	8,375.54	4,500.00	22,100.00
Fund 244 - ECONOMIC DEVELOPMENT:					
TOTAL REVENUES		17,600.00	1.72	4,500.00	22,100.00
TOTAL EXPENDITURES		17,600.00	8,375.54	4,500.00	22,100.00
NET OF REVENUES & EXPENDITURES		0.00	(8,373.82)	-	0.00

FUND: DOWNTOWN DEVELOPMENT AUTHORITY

GL NUMBER	DESCRIPTION	Original BUDGET	YTD BALANCE 4/26/2024	ADD OR SUBTRACT FROM BUDGET	2024 FIRST QTR AMENDED BUDGET
Fund 248 - D.D.A.					
248-000-402.000	CAPTURED TAXES	20,677.00	0.00		20,677.00
248-000-403.000	CAPTURE TOWNSHIP TAXES	4,075.00	4,075.39	129.00	4,204.00
248-000-404.000	CAPTURE COUNTY TAXES	9,313.00	9,312.98	295.00	9,608.00
248-000-624.000	REVENUES, BUSINESS BLDRS	0.00	0.00		0.00
248-000-625.000	MISC FEES	268.00	0.00		268.00
248-000-664.000	INTEREST & DIVIDENDS	361.00	189.51		361.00
248-000-665.200	RENTALS AND LEASES, THORP PRPTY	0.00	0.00		0.00
248-000-675.000	TRANSFER FROM FUND BALANCE	2,800.00	0.00	11,900.00	14,700.00
248-000-678.000	DONATIONS, PINNEY FOUNDATION	0.00	0.00		0.00
248-000-691.000	TRANSFER FROM GENERAL FUND	0.00	0.00		0.00
Total Dept 000		37,494.00	13,577.88	12,324.00	49,818.00

Expenditures	DESCRIPTION	Original BUDGET	YTD BALANCE 4/26/2024	ADD OR SUBTRACT FROM BUDGET	2024 FIRST QTR AMENDED BUDGET
Dept 001 - ADMINISTRATION					
248-001-706.000	SALARIES & WAGES	6,063.00	1,171.65		6,063.00
248-001-707.000	SALARIES & WAGES - PART-TIME	2,024.00	649.39		2,024.00
248-001-707.100	PT WAGES, THORP HOUSE MAINT	103.00	0.00		103.00
248-001-714.000	FRINGE BENEFITS	2,346.00	455.17		2,346.00
248-001-714.100	FRINGES, THORP HOUSE MAINT	0.00	0.00		0.00
248-001-715.000	FICA/MEDICARE	570.00	138.79		570.00
248-001-722.000	RETIREMENT	645.00	95.62		645.00
248-001-740.000	OPERATING SUPPLIES	556.00	1,961.00	1,524.00	2,080.00
248-001-800.000	CONTRACTED SERVICES	4,000.00	4,800.00	800.00	4,800.00
248-001-900.000	PRINTING AND PUBLISHING	0.00	0.00		0.00
248-001-943.000	EQUIPMENT RENTAL	9,250.00	2,429.06		9,250.00
248-001-956.000	MISC EXPENSES	1,030.00	0.00		1,030.00
248-001-960.000	PROFESSIONAL DEVELOPMENT	500.00	123.12		500.00
248-001-970.000	CAPITAL IMPROVEMENT	0.00	0.00		0.00
248-001-977.000	EQUIPMENT UNDER \$5000	0.00	0.00		0.00
248-001-990.000	FACADE INT REIMBURSEMENTS	0.00	0.00		0.00
Total Dept 001 - ADMINISTRATION		27,087.00	11,823.80	2,324.00	29,411.00

Dept 005 - THORP PROPERTY					
248-005-706.000	SALARIES & WAGES	0.00	0.00		0.00
248-005-707.000	SALARIES & WAGES - PART-TIME	500.00	0.00		500.00
248-005-714.000	FRINGE BENEFITS	100.00	0.00		100.00
248-005-715.000	FICA/MEDICARE	0.00	0.00		0.00
248-005-722.000	RETIREMENT	0.00	0.00		0.00
248-005-740.000	OPERATING SUPPLIES, THORP MT	0.00	0.00		0.00
248-005-800.000	CONTRACTED SERVICES, THORP MAINT	0.00	0.00		0.00
248-005-827.000	INSURANCE, THORP PRPTY	0.00	0.00		0.00
248-005-920.000	UTILITIES, THORP PROPERTY	0.00	0.00		0.00
Total Dept 005 - THORP PROPERTY		600.00	0.00	-	600.00

Dept 006 - BUSINESS BLDRS PROGRAM					
248-006-740.000	OPERATING SUPPLIES, BUSINESS BLDRS	0.00	0.00		0.00
248-006-800.000	CONTRACTUAL SERVICES, BUSINESS BLDRS	0.00	0.00	10,000.00	10,000.00
Net - Dept 006 - BUSINESS BLDRS PROGRAM		-	-	10,000.00	10,000.00

Dept 008 - DDA DEBT SERVICE					
248-008-991.000	LOAN PRINCIPAL PAYMENT	9,376.00	2,169.66		9,376.00
248-008-996.000	LOAN INTEREST EXPENSE	431.00	210.39		431.00
Total Dept 008 - DDA DEBT SERVICE		9,807.00	2,380.05	-	9,807.00

TOTAL EXPENDITURES		37,494.00	14,203.85	12,324.00	49,818.00
---------------------------	--	------------------	------------------	------------------	------------------

Fund 248 - D.D.A.:					
TOTAL REVENUES		37,494.00	13,577.88	12,324.00	49,818.00
TOTAL EXPENDITURES		37,494.00	14,203.85	12,324.00	49,818.00
NET OF REVENUES & EXPENDITURES		0.00	(625.97)	-	0.00

FUND: WATER RECREATION FUND		Original	YTD BALANCE	ADD OR SUBTRACT	2024 FIRST QTR
GL NUMBER	DESCRIPTION	BUDGET	4/26/2024	FROM BUDGET	AMENDED BUDGET
Fund 408 - WATER RECREATION FUND					
408-000-585.000	OTHER GRANTS, WRF	0.00	0.00		0.00
408-000-664.000	INTEREST & DIVIDENDS	0.00	0.00		0.00
408-000-674.000	POOL RENOVATION DONATIONS	0.00	0.00		0.00
408-000-675.000	DONATIONS, SPLASH PARK PROJECT	500.00	0.00		500.00
408-000-691.000	APPROPRIATION FROM FUND BAL.	0.00	0.00		0.00
408-000-699.100	TRANSFER IN FROM FUND BALANCE	0.00	0.00		0.00
Total Dept 000		500.00	0.00	-	500.00
Expenditures		Original	YTD BALANCE	ADD OR SUBTRACT	2024 FIRST QTR
Dept 001 - ADMINISTRATIC	DESCRIPTION	BUDGET	4/26/2024	FROM BUDGET	AMENDED BUDGET
408-001-740.000	SUPPLIES	500.00	0.00		500.00
408-001-977.000	EQUIPMENT UNDER \$5000	0.00	0.00		0.00
408-001-986.000	POOL CAPITAL RENOVATIONS	0.00	0.00		0.00
Total Dept 001 - ADMINISTRATION		500.00	0.00	-	500.00
Dept 002 - SPLASH PAD					
408-002-986.000	SPLASH PAD CAPITAL IMPROVEMENTS	0.00	0.00		0.00
Net - Dept 002 -SPLASH PAD		0.00	0.00	0.00	0.00
Fund 408 - WATER RECREATION FUND:					
TOTAL REVENUES		500.00	0.00	0.00	500.00
TOTAL EXPENDITURES		500.00	0.00	0.00	500.00
NET OF REVENUES & EXPENDITURES		0.00	0.00	0.00	0.00

FUND: WASTEWATER TREATMENT FUND		Original	YTD BALANCE	ADD OR SUBTRACT	2024 FIRST QTR
GL NUMBER	DESCRIPTION	BUDGET	4/26/2024	FROM BUDGET	AMENDED BUDGET
Fund 590 - WASTEWATER TREATMENT					
590-000-528.000	OTHER FEDERAL GRANTS - ARPA	245,000.00	0.00		245,000.00
590-000-609.000	SEWER MISC REVENUES	27,810.00	10,755.00		27,810.00
590-000-628.000	SEWER OMR FEES	304,707.00	77,279.74		304,707.00
590-000-629.000	SEWER USAGE FEES PER 1K GALLONS	530,184.00	125,755.10		530,184.00
590-000-636.000	SEWER CONNECTIONS	1,000.00	0.00		1,000.00
590-000-662.000	SEWER SERVICE PENALTIES	15,000.00	4,561.93		15,000.00
590-000-664.000	INTEREST & DIVIDENDS	14,500.00	2,091.00		14,500.00
590-000-699.000	TRANSFERS FROM FUND BALANCE	33,500.00	0.00		33,500.00
Total Dept 000		1,171,701.00	220,442.77	-	1,171,701.00
Expenditures					
Dept 001 - ADMINISTRATIVE		Original	YTD BALANCE	ADD OR SUBTRACT	2024 FIRST QTR
	DESCRIPTION	BUDGET	4/26/2024	FROM BUDGET	AMENDED BUDGET
590-001-706.000	SALARIES & WAGES	79,322.00	17,291.88		79,322.00
590-001-707.000	SALARIES & WAGES - PART-TIME	1,082.00	0.00		1,082.00
590-001-714.000	FRINGE BENEFITS	19,606.00	9,867.87		19,606.00
590-001-715.000	FICA/MEDICARE	4,485.00	1,596.91		4,485.00
590-001-722.000	RETIREMENT	6,265.00	2,064.16		6,265.00
590-001-726.000	CAR/VEHICLE ALLOWANCE	0.00	0.00		0.00
590-001-740.000	OPERATING SUPPLIES	4,992.00	164.60		4,992.00
590-001-800.000	ADMINISTRATION CONTRACTED SERVICES	1,000.00	568.75		1,000.00
590-001-803.000	FEES	3,448.00	260.00		3,448.00
590-001-807.000	MEMBERSHIP & DUES	1,400.00	0.00		1,400.00
590-001-826.000	SEWER LEGAL FEES	3,296.00	0.00		3,296.00
590-001-826.100	LEGAL FEES, USDA BOND PROJECT	0.00	0.00		0.00
590-001-827.000	INSURANCE & BONDS	10,011.00	0.00		10,011.00
590-001-853.000	TELEPHONE	4,030.00	1,971.79		4,030.00
590-001-860.000	TRAVEL/MEALS/LODGING	1,300.00	0.00		1,300.00
590-001-933.000	MAINTENANCE CONTRACTS EQUIPMENT	2,316.00	0.00		2,316.00
590-001-943.000	SEWER EQUIPMENT RENTAL	6,300.00	766.88		6,300.00
590-001-960.000	PROFESSIONAL DEVELOPMENT	5,400.00	3,099.30		5,400.00
590-001-963.000	ADMIN. CHARGE G.F.	84,088.00	0.00		84,088.00
590-001-968.000	SEWER DEPRECIATION	0.00	0.00		0.00
590-001-970.000	CAPITAL OUTLAY	0.00	0.00		0.00
Total Dept 001 - ADMINISTRATION		238,341.00	37,652.14	-	238,341.00
Dept 002 - TREATMENT AND PUMPING					
590-002-706.000	SALARIES & WAGES	72,780.00	24,228.88		72,780.00
590-002-707.000	SALARIES & WAGES - PART-TIME	1,379.00	279.40		1,379.00
590-002-714.000	FRINGE BENEFITS	27,517.00	15,590.65		27,517.00
590-002-715.000	FICA/MEDICARE	6,941.00	2,221.99		6,941.00
590-002-722.000	RETIREMENT	7,028.00	2,295.65		7,028.00
590-002-740.000	OPERATING SUPPLIES	17,304.00	2,839.13		17,304.00
590-002-743.000	CHEMICALS	22,000.00	16,510.51		22,000.00
590-002-800.000	CONTRACTED SERVICES	28,625.00	5,520.48		28,625.00
590-002-800.100	CONTRACTUAL ENGINEERING, ARPA	270,000.00	142,222.00		270,000.00
590-002-853.000	COMMUNICATIONS	1,125.00	0.00		1,125.00
590-002-920.000	UTILITIES	92,527.00	27,850.73		92,527.00
590-002-933.000	REPAIR & MAINTENANCE	5,793.00	151.56		5,793.00
590-002-943.000	EQUIPMENT RENTAL	1,700.00	0.00		1,700.00
590-002-965.000	INTEREST EXPENSE	1,133.00	0.00		1,133.00
590-002-970.000	CAPITAL OUTLAY	30,000.00	13,122.79		30,000.00
590-002-970.100	CAPITAL OUTLAY, GIS SYSTEM	0.00	0.00		0.00
590-002-977.000	EQUIPMENT UNDER \$5000	2,000.00	0.00		2,000.00
Total Dept 002 - TREATMENT AND PUMPING		587,852.00	252,833.77	-	587,852.00
Dept 003 - COLLECTIONS					
590-003-706.000	SALARIES & WAGES	18,102.00	3,964.10		18,102.00
590-003-707.000	SALARIES & WAGES - PART-TIME	1,622.00	377.03		1,622.00
590-003-714.000	FRINGE BENEFITS	8,684.00	1,025.94		8,684.00
590-003-715.000	FICA/MEDICARE	6,283.00	330.26		6,283.00
590-003-722.000	RETIREMENT	2,017.00	351.93		2,017.00
590-003-740.000	OPERATING SUPPLIES	6,695.00	24.67		6,695.00
590-003-800.000	CONTRACTED SERVICES	8,240.00	3,227.50		8,240.00
590-003-943.000	EQUIPMENT RENTAL	26,000.00	2,908.07		26,000.00
590-003-945.000	BUILDING LEASE EXPENSE	7,800.00	0.00		7,800.00
590-003-970.000	CAPITAL OUTLAY	108,000.00	7,800.00		108,000.00
590-003-975.000	RESERVE EXP, CAPITAL IMPROV	0.00	0.00		0.00
Total Dept 003 - COLLECTIONS		193,443.00	20,009.50	-	193,443.00

GL NUMBER	DESCRIPTION	Original BUDGET	YTD BALANCE 4/26/2024	ADD OR SUBTRACT FROM BUDGET	2024 FIRST QTR AMENDED BUDGET
Dept 004 - MAINTENANCE					
590-004-706.000	SALARIES & WAGES	63,846.00	32,009.44		63,846.00
590-004-707.000	SALARIES & WAGES - PART-TIME	10,779.00	472.50		10,779.00
590-004-714.000	FRINGE BENEFITS	29,219.00	12,852.09		29,219.00
590-004-715.000	FICA/MEDICARE	7,324.00	2,481.20		7,324.00
590-004-722.000	RETIREMENT	9,966.00	3,018.03		9,966.00
590-004-740.000	OPERATING SUPPLIES	10,179.00	576.99		10,179.00
590-004-800.000	CONTRACTED SERVICES	5,650.00	0.00		5,650.00
590-004-933.000	REPAIR & MAINTENANCE	13,519.00	0.00		13,519.00
590-004-943.000	EQUIPMENT RENTAL	0.00	0.00		0.00
590-004-970.000	CAPITAL OUTLAY	0.00	0.00		0.00
590-004-977.000	EQUIPMENT UNDER \$5000	1,125.00	0.00		1,125.00
590-004-995.000	INTEREST AND PRINCIPAL EXPENSE	0.00	0.00		0.00
Total Dept 004 - MAINTENANCE		151,607.00	51,410.25	-	151,607.00
TOTAL EXPENDITURES		1,171,243.00	361,905.66	-	1,171,243.00
Fund 590 - WASTEWATER TREATMENT:					
TOTAL REVENUES		1,171,701.00	220,442.77	-	1,171,701.00
TOTAL EXPENDITURES		1,171,243.00	361,905.66	-	1,171,243.00
NET OF REVENUES & EXPENDITURES		458.00	(141,462.89)	-	458.00

FUND: WATER		Original	YTD BALANCE	ADD OR SUBTRACT	2024 FIRST QTR
GL NUMBER	DESCRIPTION	BUDGET	4/26/2024	FROM BUDGET	AMENDED BUDGET
Fund 591 - WATER SYSTEM					
591-000-544.000	STATE GRANT - DWAM	103,228.00	0.00		103,228.00
591-000-628.000	WATER OMR FEES	320,678.00	108,296.00		320,678.00
591-000-629.000	WATER USAGE FEES PER 1000 GALLONS	387,139.00	51,216.10		387,139.00
591-000-636.000	CONNECTIONS	1,000.00	0.00		1,000.00
591-000-642.000	METER CHARGES	0.00	0.00		0.00
591-000-646.000	BULK WATER SALES REVENUIE	2,200.00	371.00		2,200.00
591-000-662.000	SERVICE PENALTIES	11,500.00	2,946.87		11,500.00
591-000-663.000	WATER, INSURANCE PROCEEDS	0.00	0.00		0.00
591-000-664.000	INTEREST & DIVIDENDS	15,500.00	6,306.28	5,000.00	20,500.00
591-000-665.000	BUILDING LEASE REVENUES	53,024.00	0.00		53,024.00
591-000-671.000	MISC. REIMBURSEMENTS	6,900.00	125.00		6,900.00
591-000-675.000	CONTRIBUTIONS FROM COUNTY	0.00	0.00		0.00
591-000-699.000	TRANSFERS FROM FUND BALANCE	0.00	0.00		0.00
Total Dept 000		901,169.00	169,261.25	5,000.00	906,169.00

Expenditures		Original	YTD BALANCE	ADD OR SUBTRACT	2024 FIRST QTR
Dept 001 - ADMINISTRATIC	DESCRIPTION	BUDGET	4/26/2024	FROM BUDGET	AMENDED BUDGET
591-001-706.000	SALARIES & WAGES	79,322.00	19,075.14	(700.00)	78,622.00
591-001-707.000	SALARIES & WAGES - PART-TIME	0.00	26.93	700.00	700.00
591-001-708.000	SALARIES-SAMPLES	2,859.00	233.78		2,859.00
591-001-714.000	FRINGE BENFITS	25,963.00	8,399.26		25,963.00
591-001-715.000	FICA/MEDICARE	5,317.00	1,549.33		5,317.00
591-001-722.000	RETIREMENT	6,303.00	2,076.96		6,303.00
591-001-726.000	CAR/VEHICLE ALLOWANCE	0.00	0.00		0.00
591-001-740.000	OPERATING SUPPLIES	2,250.00	475.89		2,250.00
591-001-800.000	ADMINISTRATION CONTRACTED SERVICES	646.00	568.75		646.00
591-001-800.100	CONTRACTUAL SERV, USDA BOND PROJECT	0.00	0.00		0.00
591-001-803.000	FEES	1,813.00	1,043.11		1,813.00
591-001-807.000	MEMBERSHIP & DUES	1,000.00	0.00		1,000.00
591-001-826.000	LEGAL EXPENSES	0.00	0.00		0.00
591-001-826.100	LEGAL FEES, USDA BOND PROJECT	0.00	0.00		0.00
591-001-827.000	INSURANCE & BONDS	4,161.00	0.00		4,161.00
591-001-853.000	COMMUNICATIONS	2,000.00	1,128.82		2,000.00
591-001-860.000	TRAVEL/MEALS/LODGING	1,100.00	19.83		1,100.00
591-001-933.000	MAINTENANCE CONTRACTS EQUIPMENT	4,100.00	212.24		4,100.00
591-001-943.000	EQUIPMENT RENTAL	7,000.00	1,242.34		7,000.00
591-001-960.000	PROFESSIONAL DEVELOPMENT	7,500.00	2,096.69		7,500.00
591-001-963.000	ADMIN. CHARGE G.F.	60,454.00	0.00		60,454.00
591-001-968.000	DEPRECIATION	0.00	0.00		0.00
591-001-970.000	CAPITAL OUTLAY	0.00	0.00		0.00
591-001-977.000	EQUIPMENT UNDER \$5000	2,000.00	0.00		2,000.00
Total Dept 001 - ADMINISTRATION		213,788.00	38,149.07	-	213,788.00

Dept 002 - TREATMENT AND PUMPING					
Dept 002 - TREATMENT AND PUMPING					
591-002-706.000	SALARIES & WAGES	24,664.00	2,468.62		24,664.00
591-002-714.000	FRINGE BENFITS	16,750.00	1,011.30		16,750.00
591-002-715.000	FICA/MEDICARE	1,848.00	188.64		1,848.00
591-002-722.000	RETIREMENT	2,054.00	250.29		2,054.00
591-002-740.000	OPERATING SUPPLIES	10,815.00	568.09		10,815.00
591-002-743.000	CHEMICALS	21,630.00	3,645.00		21,630.00
591-002-800.000	CONTRACTED SERVICES	16,777.00	2,813.86		16,777.00
591-002-802.000	WATER QUALITY TESTING FEES	2,704.00	0.00		2,704.00
591-002-826.000	LEGAL & PROFESSIONAL, FMB 2021 BONDS	0.00	0.00		0.00
591-002-853.000	TELEPHONE EXPENSE	3,491.00	443.94		3,491.00
591-002-920.000	UTILITIES	59,483.00	10,703.75		59,483.00
591-002-933.000	REPAIR AND MAINTENANCE	7,138.00	0.00		7,138.00
591-002-943.000	EQUIPMENT RENTAL	2,250.00	0.00		2,250.00
591-002-965.000	ATRP INTEREST EXPENSE	10,000.00	15,000.00	5,000.00	15,000.00
591-002-965.100	INTEREST EXPENSE/SEEGER ST	10,000.00	7,155.00		10,000.00
591-002-970.000	CAPITAL OUTLAY	60,000.00	0.00		60,000.00
591-002-970.100	CAPITAL OUTLAY, GIS SYSTEM	0.00	0.00		0.00
591-002-975.000	RESERVE EXP, MAJOR CAPITAL IMPROV	0.00	0.00		0.00
591-002-976.000	RESERVE EXP, REPAIR/REPLACEMENT	0.00	0.00		0.00
591-002-977.000	EQUIPMENT UNDER \$5000	4,200.00	0.00		4,200.00
Total Dept 002 - TREATMENT AND PUMPING		253,804.00	44,248.49	5,000.00	258,804.00

Dept 003 - COLLECTIONS					
591-003-706.000	SALARIES & WAGES	40,843.00	6,984.79	40,843.00	
591-003-707.000	SALARIES & WAGES - PART-TIME	1,125.00	619.39	1,125.00	
591-003-714.000	FRINGE BENEFITS	15,955.00	3,159.13	15,955.00	
591-003-715.000	FICA/MEDICARE	4,559.00	667.36	4,559.00	
591-003-722.000	RETIREMENT	5,235.00	805.12	5,235.00	
591-003-740.000	OPERATING SUPPLIES	9,729.00	2,786.00	9,729.00	
591-003-800.000	CONTRACTED SERVICES	35,000.00	1,550.00	35,000.00	
591-003-800.100	CONTRACTUAL SERV, USDA PROJ PRELIM ENG	0.00	0.00	0.00	
591-003-800.200	CONTRACTUAL, WALBRO PROJ ENGINEERING	0.00	0.00	0.00	
591-003-800.300	CONTRACTUAL, USDA PROJECT CONSTRUCTION	0.00	0.00	0.00	
591-003-943.000	EQUIPMENT RENTAL	25,000.00	2,484.45	25,000.00	
591-003-965.000	SSP LOAN INTEREST PAYMENT	0.00	0.00	0.00	
591-003-970.000	CAPITAL OUTLAY	13,000.00	0.00	15,000.00	
591-003-977.000	EQUIPMENT, UNDER 5K	0.00	0.00	0.00	
Total Dept 003 - COLLECTIONS		152,446.00	19,056.24	-	152,446.00

GL NUMBER	DESCRIPTION	Original BUDGET	YTD BALANCE 4/26/2024	ADD OR SUBTRACT FROM BUDGET	2024 FIRST QTR AMENDED BUDGET
Dept 004 - MAINTENANCE					
591-004-706.000	SALARIES & WAGES	3,861.00	646.32		3,861.00
591-004-707.000	SALARIES & WAGES - PART-TIME	0.00	0.00		0.00
591-004-714.000	FRINGE BENEFITS	1,731.00	262.07		1,731.00
591-004-715.000	FICA/MEDICARE	598.00	49.41		598.00
591-004-722.000	RETIREMENT	542.00	12.92		542.00
591-004-740.000	OPERATING SUPPLIES	1,368.00	0.00		1,368.00
591-004-800.000	CONTRACTED SERVICES	1,082.00	0.00		1,082.00
591-004-933.000	REPAIR & MAINTENANCE	9,734.00	63.59		9,734.00
591-004-943.000	EQUIPMENT RENTAL	1,500.00	15.33		1,500.00
591-004-970.000	CAPITAL OUTLAY	0.00	0.00		0.00
591-004-977.000	EQUIPMENT, UNDER 5K	1,500.00	0.00		1,500.00
Total Dept 004 - MAINTENANCE		21,916.00	1,049.64	-	21,916.00

Dept 011 - DWAM GRANT					
591-011-706.000	SALARIES & WAGES	3,605.00	2,164.03		3,605.00
591-011-707.000	SALARIES & WAGES - PART-TIME	0.00	0.00		0.00
591-011-714.000	FRINGE BENEFITS	1,288.00	111.16		1,288.00
591-011-715.000	FICA/MEDICARE	258.00	164.92		258.00
591-011-722.000	RETIREMENT	515.00	228.94		515.00
591-011-800.100	DWAM, CONTRACTUAL SERV, AMP	23,912.00	0.00		23,912.00
591-011-800.200	DWAM, CONTRACTUAL SERV, DSMI	64,551.00	0.00		64,551.00
591-011-943.000	EQUIPMENT RENTAL	8,000.00	0.00		8,000.00
591-011-970.000	DWAM, EQUIPMENT	1,099.00	0.00		1,099.00
Net - Dept 011 - DWAM GRANT		103,228.00	2,669.05	0.00	103,228.00

TOTAL EXPENDITURES		745,182.00	105,172.49	5,000.00	750,182.00
--------------------	--	------------	------------	----------	------------

Fund 591 - WATER SYSTEM:					
TOTAL REVENUES		901,169.00	169,261.25	5,000.00	906,169.00
TOTAL EXPENDITURES		745,182.00	105,172.49	5,000.00	750,182.00
NET OF REVENUES & EXPENDITURES		155,987.00	64,088.76	-	155,987.00

FUND: MOTOR VEHICLE FUND		Original	YTD BALANCE	ADD OR SUBTRACT	2024 FIRST QTR
GL NUMBER	DESCRIPTION	BUDGET	4/26/2024	FROM BUDGET	AMENDED BUDGET
Fund 651 - MOTOR VEHICLE & EQUIPMENT					
651-000-654.000	DPW CONTRACTING REVENUES	1,545.00	0.00		1,545.00
651-000-663.000	MVF, INSURANCE PROCEEDS	0.00	0.00		0.00
651-000-664.000	INTEREST & DIVIDENDS	10,000.00	5,790.26		10,000.00
651-000-670.000	INTERDEPARTMENT RENTALS	435,720.00	85,947.87		435,720.00
651-000-671.000	MISC REIMBURSEMENTS	400.00	0.00		400.00
651-000-673.000	SALE OF ASSETS	12,000.00	0.00		12,000.00
651-000-699.000	TRANSFER FROM FUND BALANCE	91,000.00	0.00		91,000.00
Total Dept 000		550,665.00	91,738.13	-	550,665.00

Expenditures		Original	YTD BALANCE	ADD OR SUBTRACT	2024 FIRST QTR
Dept 001 - ADMINISTRATIK	DESCRIPTION	BUDGET	4/26/2024	FROM BUDGET	AMENDED BUDGET
651-001-706.000	SALARIES & WAGES	57,682.00	13,285.18		57,682.00
651-001-707.000	SALARIES & WAGES - PART-TIME	3,937.00	2,650.45		3,937.00
651-001-714.000	FRINGE BENEFITS	19,374.00	6,709.49		19,374.00
651-001-715.000	FICA/MEDICARE	3,563.00	1,335.23		3,563.00
651-001-722.000	RETIREMENT	4,476.00	1,529.75		4,476.00
651-001-740.000	SUPPLIES	16,500.00	3,289.38		16,500.00
651-001-751.000	GAS & OIL	59,000.00	9,838.53		59,000.00
651-001-827.000	VEHICLE INSURANCE	24,000.00	0.00		24,000.00
651-001-853.000	TELEPHONE EXPENSE	438.00	160.00		438.00
651-001-860.000	TRAVEL/MEALS/LODGING	580.00	0.00		580.00
651-001-933.000	REPAIR & MAINTENANCE	43,500.00	16,710.14		43,500.00
651-001-945.000	BUILDING LEASE EXPENSE	42,700.00	0.00		42,700.00
651-001-960.000	PROFESSIONAL DEVELOPMENT	160.00	0.00		160.00
651-001-963.000	ADMIN CHARGE GF	23,789.00	0.00		23,789.00
651-001-968.000	DEPRECIATION	0.00	0.00		0.00
651-001-970.000	CAPITAL OUTLAY	241,520.00	0.00		241,520.00
651-001-975.000	RESERVE EXP, MAJOR CAPITAL IMPROV	0.00	0.00		0.00
651-001-976.000	LOSS OF DISPOSAL OF FIXED ASSET	0.00	0.00		0.00
651-001-977.000	EQUIPMENT UNDER \$5000	9,167.00	0.00		9,167.00
651-001-996.000	INTEREST EXPENSE	0.00	0.00		0.00
651-001-999.000	TRANSFERS OUT	0.00	0.00		0.00
Total Dept 001 - ADMINISTRATION		550,386.00	55,508.15	-	550,386.00

Fund 651 - MOTOR VEHICLE & EQUIPMENT:					
TOTAL REVENUES		550,665.00	91,738.13	-	550,665.00
TOTAL EXPENDITURES		550,386.00	55,508.15	-	550,386.00
NET OF REVENUES & EXPENDITURES		279.00	36,229.98	-	279.00

IN SUMMARY:					
TOTAL VOCC REVENUES - ALL FUNDS		5,764,477.00	731,673.55	25,649.00	5,790,126.00
TOTAL VOCC EXPENDITURES - ALL FUNDS		5,606,378.00	1,205,317.17	25,649.00	5,632,027.00
NET OF REVENUES & EXPENDITURES		158,099.00	(473,643.62)	0.00	158,099.00



TO: Village President and Council
FROM: Debbie Powell, Village Manager
DATE: April 29, 2024
SUBJECT: Approve Employee Insurance Renewal with Sun Life Assurance

It is time to renew our Insurance Policies with Sun Life Assurance. This is an insurance package with a policy period of one year, 7/1/24 to 7/1/25. The insurance policy provides our employees with Life insurance at \$10,571 per year, Accidental Death, and Dismemberment at \$686 per year, and Short-Term Disability at \$17,464 per year. The Sun Life Assurance proposal has the same rates as last year, for nineteen employees.

It is recommended to renew the insurance policy with Sun Life Assurance.

MOTION: Approve Renewal with Sun Life Assurance for employee life, accidental death and dismemberment, and short-term disability for one-year effective July 1, 2024, in the total amount of \$28,721.

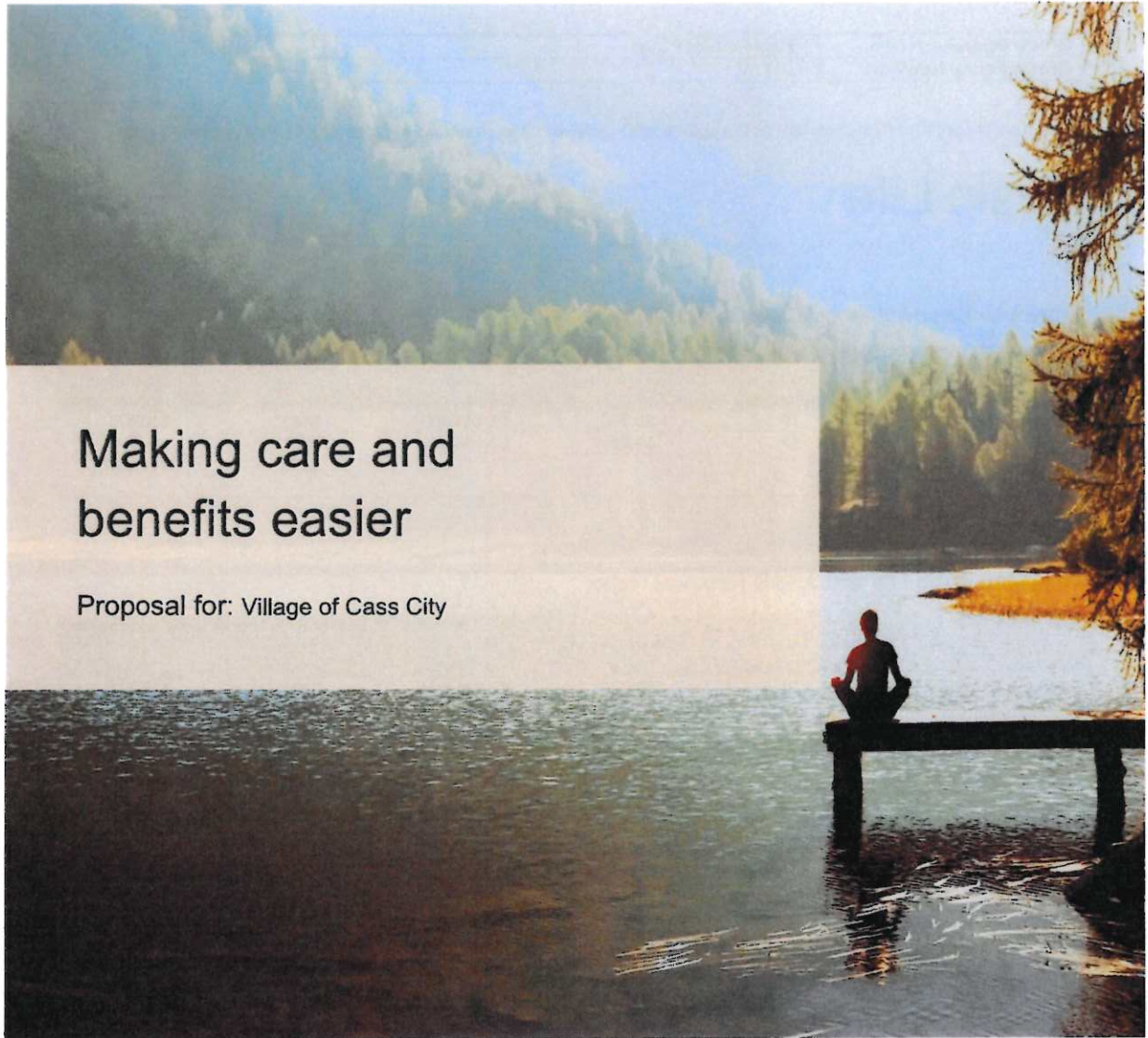

Renewal Rates Section

Renewal Effective Date: July 1, 2024

Group Sponsor Name:	Village of Cass City
Group Policy Number:	930314

Sun Life will continue this coverage at the referenced renewal rates provided that premium owed is paid to date.

Basic Life

Employee Basic Life and AD&D Current Rates

Coverage	Total employees	Current monthly rate	Total current monthly volume	Total current monthly premium	Total current annual premium
Employee Basic Life	19	\$0.770	\$1,144,000	\$881	\$10,571
Employee Basic AD&D	19	\$0.050	\$1,144,000	\$57	\$686
Total current premium				\$938	\$11,257

Rate basis: Per \$1,000 of volume

Employee Basic Life and AD&D Renewal Rates

Coverage	Total employees	Monthly rate	Total estimated monthly volume	Total estimated monthly premium	Total estimated annual premium
Employee Basic Life	19	\$0.770	\$1,144,000	\$881	\$10,571
Employee Basic AD&D	19	\$0.050	\$1,144,000	\$57	\$686
Total estimated premium				\$938	\$11,257

Rate basis: Per \$1,000 of volume

Group Basic Life and AD&D coverage is underwritten by Sun Life Assurance Company of Canada (Wellesley Hills, MA) under Policy Form Series 15-GP-01.

Employee Basic Life

Renewal Rate Rationale

In determining your new plan rate(s), we have reviewed your past claims experience and your current demographics, including average age, gender distribution, and benefit distribution. The change in one or more of these factors has brought about an adjustment to the group insurance rate(s).

Group Basic Life and AD&D coverage is underwritten by Sun Life Assurance Company of Canada
(Wellesley Hills, MA) under Policy Form Series 15-GP-01.

Proposal for Village of Cass City
Page 3 of 10

February 8, 2024
Case ID: 2349662
rev. 06090615 GGOT-1288

Short Term Disability

Short-Term Disability Current Rates

Coverage	Total participating employees	Current monthly rate	Total current volume	Total current monthly premium	Total current annual premium
STD	19	\$1.300	\$11,195	\$1,455	\$17,464
Rate basis: Per \$10 of weekly benefit					

Short-Term Disability Renewal Rates

Coverage	Total participating employees	Monthly rate	Total estimated volume	Total estimated monthly premium	Total estimated annual premium
STD	19	\$1.300	\$11,195	\$1,455	\$17,464
Rate basis: Per \$10 of weekly benefit					

Group Short-Term Disability coverage is underwritten by Sun Life Assurance Company of Canada (Wellesley Hills, MA) under Policy Form Series 15-GP-01.

Short-Term Disability

Renewal Rate Rationale

Group Short-Term Disability coverage is underwritten by Sun Life Assurance Company of Canada
(Wellesley Hills, MA) under Policy Form Series 15-GP-01.

Proposal for Village of Cass City
Page 5 of 10

February 8, 2024
Case ID: 2349662
rev. 06090615 GGOT-1288

Basic Life

Plan design and rates

Employee Basic Life and AD&D plan design

Employee Basic Life	
Eligible employees	All Full-Time United States Employees working in the United States who are scheduled to work a minimum of 30 hours per week
Effective Date	July 1, 2024
Class 1	
Class description	All Eligible Employees
Waiting Period	30 days of employment
Benefit amount	1 times annual earnings
Maximum benefit	\$100,000
Guaranteed Issue amount	Up to the maximum benefit
Contributions	Noncontributory
Participation requirement	100%

Employee Basic AD&D	
Eligible employees	All Full-Time United States Employees working in the United States who are scheduled to work a minimum of 30 hours per week
Effective Date	July 1, 2024
Class 1	
Class description	All Eligible Employees
Benefit amount	1 times annual earnings
Maximum benefit	\$100,000
Compulsory coverage	Yes
Contributions	Noncontributory
Participation requirement	100%

Basic Life rates

Coverage	Total employees	Monthly rate	Total estimated monthly volume	Total estimated monthly premium	Total estimated annual premium
Employee Basic Life	19	\$0.770	\$1,144,000	\$881	\$10,571
Employee Basic AD&D	19	\$0.050	\$1,144,000	\$57	\$686
Total estimated premium				\$938	\$11,257
Rate basis: Per \$1,000 of volume					
Sequence Number: 2					

Group Basic Life and AD&D coverage is underwritten by Sun Life Assurance Company of Canada (Wellesley Hills, MA) under Policy Form Series 15-GP-01.

Included in this plan:

- A flat 5% broker commission
- 24-month rate guarantee from the Effective Date
- Employee age reductions: All coverage amounts reduce to 50% at age 70, 40% at age 75, 20% at age 80 rounded to the next highest \$1,000.
- Waiver of Premium: For employees with an approved disability prior to age 60, premium is waived until age 60 or for 12 months (whichever is later). For employees disabled on or after age 60 but prior to age 65, premium is waived for 12 months. There is an Elimination Period of 6 months which must be satisfied before the waiver of premium begins. The definition of Total Disability is disabled from any occupation.

Waiver of premium is provided on the following benefits: Employee Basic Life and Employee Basic AD&D.

- Conversion Privilege
- Employee Accelerated Death Benefit of 80% to a maximum of \$250,000.
- A choice of one Value-Added Service: Self Care+, Emergency Travel Assistance & ID Theft, or Online Will Preparation & Claimant Support Services.²
- Coverage will be continued on a premium-paying basis for a period of 3 months during a layoff.
- Coverage will be continued on a premium-paying basis for a period of 3 months during a leave of absence approved by the policyholder.
- Coverage will be continued on a premium-paying basis for a period of 12 months during a period of injury or sickness.
- Employee coverage is rounded to the next highest \$1,000.
- Earnings definition: Earnings are defined as the current earnings reported by the employer. Earnings include deductions made for pre-tax contributions to a qualified deferred compensation plan, Section 125 plan, or flexible spending account. Earnings do not include commissions, bonuses, overtime, or any other compensation.
- 24-hour AD&D coverage
- Special AD&D benefits:
 - Dependent Education-Child
 - Seat Belt

Footnote information is located in the General Disclosures section on the last page of this proposal.

Group Basic Life and AD&D coverage is underwritten by Sun Life Assurance Company of Canada
(Wellesley Hills, MA) under Policy Form Series 15-GP-01.

Assumptions

- Notification of any employer-completed merger or acquisition.
- Evidence of Insurability is required for late entrants, coverage increases, and coverage in excess of the Guaranteed Issue amount.

Group Life and AD&D coverage is underwritten by Sun Life Assurance Company of Canada
(Wellesley Hills, MA) under Policy Form Series 15-GP-01.

Short-Term Disability

Plan design and rates

Short-Term Disability plan design

Eligible employees	All Full-Time United States Employees working in the United States who are scheduled to work a minimum of 30 hours per week
Effective Date	July 1, 2024
	Class 1:
Class description	All Eligible Employees
Waiting Period	30 days of employment
Benefit amount	67.77%
Maximum weekly benefit	\$600
Definition of Disability	loss of duties and loss of earnings required
Minimum weekly benefit	\$25
Injury start date	1 day
Sickness start date	8 days
First-Day Hospitalization	No
Maximum Benefit Period	26 weeks
Partial Disability benefit	Return-to-Work
Zero-Day Residual	No
Pre-Existing Limitation	None
Contributions	Non-contributory
Participation requirement	100%
Employer contribution %	100%

Short-Term Disability Rates

Coverage	Total participating employees	Monthly rate	Total estimated volume	Total estimated monthly premium	Total estimated annual premium
STD	19	\$1,300	\$11,195	\$1,455	\$17,464

Rate basis: Per \$10 of weekly benefit
Sequence Number: 4

Included in this plan:

- Sun Life's AEB Life STD Standard Graded Scale 10% broker commission
- 12-month rate guarantee from the Effective Date
- Disability management services
- Partial Disability benefit
- No offsets for statutory STD plans
- No offsets for other income (non-integrated plan)
- Employer FICA administration for any taxable benefits not included
- Full maternity coverage
- Nonoccupational coverage
- Earnings definition: Earnings are defined as the earnings reported by the employer immediately prior to the first date of disability. Earnings include deductions made for pre-tax contributions to a qualified deferred compensation plan, Section 125 plan, or flexible spending account and commissions averaged over 12 months. Earnings do not include bonuses, overtime, or any other compensation.

Group Short-Term Disability coverage is underwritten by Sun Life Assurance Company of Canada (Wellesley Hills, MA) under Policy Form Series 15-GP-01.

Assumptions

- This plan does not replace the statutory disability plan in any state.
- The employer has not opted out of Workers' Compensation coverage.
- Notification of any employer-completed merger or acquisition.

Group Short-Term Disability coverage is underwritten by Sun Life Assurance Company of Canada
(Wellesley Hills, MA) under Policy Form Series 15-GP-01.

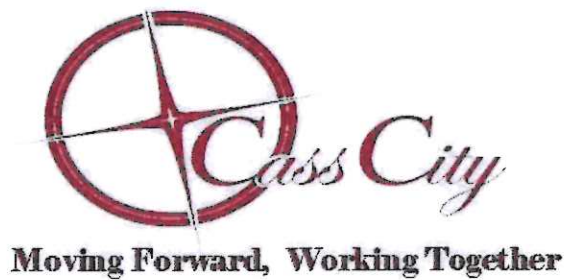

TO: Village President & Council
FROM: Debbie Powell, Village Manager
DATE: April 29, 2024
SUBJECT: Marketing RFP Recommendation

As part of the 2024 Strategic Plan, an RFP was developed for a new Logo, Marketing and Branding for the Village of Cass City. The funding for this project is to be paid from the MEDC, RRC Toolbox money that the Village was awarded. The Village of Cass City has budgeted for the 25% match for this program, in the amount of \$7,500, with total project costs not to exceed \$30,000.

Six marketing agencies were recommended through various sources, and each was sent a copy of our RFP. Three agencies responded with bid proposals before our deadline of March 28, 2024: New Moon Visions, Guello Marketing and Destination by Design.

The sealed bids were opened on April 5, 2024, with the Village Manager, Village Clerk/Treasurer, and the Director of Community Development present. A sub-committee was formed to review and score these bids as outlined in our RFP scoring matrix. This committee met on April 24, 2024, and agreed to recommend the agency, New Moon Visions, to proceed with interviewing and refining their proposal to match our needs and budget as outlined.

MOTION: To approve Debbie Powell, Village Manager, to conduct an interview and finalize and execute a marketing agreement with New Moon Visions, for a new logo, marketing and branding of the Village of Cass City, not to exceed a total of \$30,000 in funds available from the MEDC RRC Toolbox.



Moving Forward Working Together

TO: Village President and Council
FROM: Deboria L. Powell, Village Manager
DATE: April 29, 2024
SUBJECT: Approve Quote from Dean Alexander Concrete for Sidewalk Repair

Through history, we have struggled to receive bids for sidewalk repair. So, for 2024 we contacted local companies to quote our sidewalk work (Dean Alexander Concrete, Osentoski Builders, CLS Management LLC, and Creative Concrete.) The total lineal ft of sidewalk to be completed in 2024 is 979ft. This includes the worst areas of sidewalk along Maple St, Huron St. Woodland a section on Main St. near Taco Bell among other areas plus many areas that sidewalk has been removed and not replaced from past water and sewer work.

Quotes were received until April 25, 2024 they were as follows:

- Creative Concrete: \$42,230.00
- Dean Alexander Concrete: \$40,530.60
- Osentoski Builders: \$41,500.00
- CLS Management LLC \$42,856.00

We recommended the quote by Dean Alexander Concrete to perform our 2024 sidewalk work for the Village. We have \$20,000 for Local sidewalks, \$20,000 for Major sidewalks and \$10,000 for the 50/50 match. The quote by Dean Alexander Concrete will leave us funds for any emergency sidewalk work, if needed in 2024.

**MOTION: Approve the low quote by Dean Alexander Concrete for the 2024 village sidewalk work in the amount of \$40,530.60 plus a 5% contingency.
(202-470-800/203-470-800)**

In accordance with Federal Law and U.S. Department of Agriculture policy, this institution is prohibited from discriminating on the basis of race, color, national origin, sex, age or disability.

This institution is an equal opportunity provider and employer.

6506 Main St., P.O. Box 123, Cass City, MI 48726 * 989-872-2911 * Fax 989-872-4855 *
TTY 989-872-4742 or e-mail: casscity.org

DEAN ALEXANDER
 6051 Elmwood Rd
 Cass City MI 48726
 9780
 48726

Invoice

SOLD TO Village of Cass City	SHIP TO RJ
ADDRESS	ADDRESS
CITY, STATE, ZIP	CITY, STATE, ZIP

CUSTOMER ORDER NO.	SOLD BY	TERMS	F.O.B.	DATE 4-18-24
--------------------	---------	-------	--------	-----------------

ORDERED	SHIPPED	DESCRIPTION	PRICE	UNIT	AMOUNT
		11414 SHERMAN 275 FT			
		6527 HARON 40 FT			
		6603 HARON 15 FT			
		6628 HARON 9 FT			
		6651 HARON 5 FT			37011.60
		6733 MAIN 26 FT	Daycare		3579
		4320 AVE 10 FT			
		4324 MAPLE 117 FT			
		5324 MAPLE 203 FT			
		6044 S. M. ST 20 FT			
		4320 W. 1st 35' 443' 100' 110' 150'			
		DAYCARE 3925 FT			
			TOTAL		\$ 40,530.60

© adams 5840

09-15



Moving Forward Working Together

TO: Village President and Council
FROM: Deboria L. Powell, Village Manager
DATE: April 29, 2024
SUBJECT: Approval of Proposal for Salt truck from Tri County International

We would like to purchase a 2025 International HV607 salt/plow truck for the DPW. Currently the DPW has two similar trucks in the fleet, a 1998 F-700 and a 2014 International. The 1998 F-700 has not been dependable when needed during snows and salting.

These trucks are used primarily for snow plowing and salting of all streets. We need to have 3 plow trucks, 2 with salting capabilities, available during the winter to remove snow/ice efficiently.

The new HV607 will be purchased outright from Tri County International Trucks. The truck will be purchased through the MIDEAL program. With this agreement the truck may take up to 2 years to be built. So, the total cost of the International chassis today is \$95,556.01 which may be higher in 2 years.

The HV607 will be a standard cab with 37,000 gvwr. This agreement for order is only the truck chassis and all equipment shall be purchased separately.

We have funds available and will hold in a restricted fund balance until delivery.

MOTION: Approve the signing of proposal 20608-1 for the specifications for ordering a 2025 International HV607 chassis from Tri County International Trucks.

In accordance with Federal Law and U.S. Department of Agriculture policy, this institution is prohibited from discriminating on the basis of race, color, national origin, sex, age or disability.

This institution is an equal opportunity provider and employer.

6506 Main St., P.O. Box 123, Cass City, MI 48726 * 989-872-2911 * Fax 989-872-4855 *
TTY 989-872-4742 or e-mail: casscity.org

Prepared For:
 Village of Cass City
 RJ Klaus
 6506 Main St.
 Cass City, MI 48726-1524
 (989)872 - 2214
 Reference ID: N/A

Presented By:
 TRI COUNTY INTL TRUCKS
 Jeremy Kast
 3001 E HIGH ST
 JACKSON MI 49203
 (517)783-2721

Tri County International Trucks, Inc./State of Michigan DTMB Contract 240000000096, Specification #3958 0160D-Option B for a new 2025 MY International Truck Chassis per this proposal. Pricing includes all user specified option equipment costs and available discounts in effect as of date listed. Please note that the afforded pricing includes a 1% fee paid to the state of Michigan as required under this contract. Additional surcharge requirements as issued by the manufacturer may be applicable in the future.

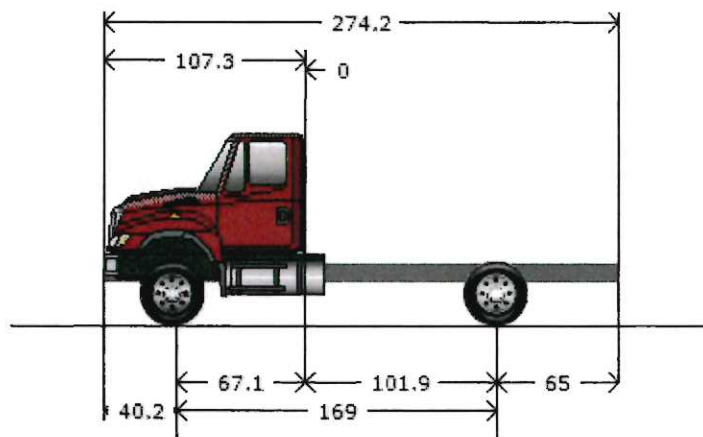

Michigan MI Deal Quote

Model Profile
2025 HV607 SBA (HV607)

- AXLE CONFIG:** 4X2
- MISSION:** Requested GVWR: 37000. Calc. GVWR: 37240. Calc. GCWR: 80000
 Calc. Start / Grade Ability: 43.47% / 2.82% @ 55 MPH
 Calc. Geared Speed: 70.6 MPH
- DIMENSION:** Wheelbase: 169.00, CA: 101.90, Axle to Frame: 65.00
- ENGINE, DIESEL:** {Cummins L9 300} EPA 2024, 300HP @ 2200 RPM, 860 lb-ft Torque @ 1200 RPM, 2200 RPM Governed Speed, 300 Peak HP (Max)
- TRANSMISSION, AUTOMATIC:** {Allison 3500 RDS} 6th Generation Controls, Wide Ratio, 6-Speed with Double Overdrive, with PTO Provision, Less Retarder, Includes Oil Level Sensor, with 80,000-lb GVW and GCW Max, On/Off Highway
- CLUTCH:** Omit Item (Clutch & Control)
- AXLE, FRONT NON-DRIVING:** {Meritor MFS-16-143A} Wide Track, I-Beam Type, 16,000-lb Capacity
- AXLE, REAR, SINGLE:** {Meritor RS-26-185} Single Reduction, 26,000-lb Capacity, Driver Controlled Locking Differential, R Wheel Ends Gear Ratio: 5.86
- CAB:** Conventional, Day Cab
- TIRE, FRONT:** (2) 11R22.5 Load Range H HSR 3 (CONTINENTAL), 494 rev/mile, 75 MPH, All-Position
- TIRE, REAR:** (4) 11R22.5 Load Range H HDR2+ (CONTINENTAL), 491 rev/mile, 75 MPH, Drive
- SUSPENSION, REAR, SINGLE:** 31,000-lb Capacity, Vari-Rate Springs, with 4500-lb Capacity Auxiliary Rubber Springs
- PAINT:** Cab schematic 100WL
 Location 1: 2303, Red (Std)
 Chassis schematic N/A

Code	Description	F/R Wt Tot Wt	
		(lbs)	(lbs)
HV60700	Base Chassis, Model HV607 SBA with 169.00 Wheelbase, 101.90 CA, and 65.00 Axle to Frame.	6136/3644	9780

AXLE CONFIGURATION

1ANA	AXLE CONFIGURATION {Navistar} 4x2	-29/-106	-135
	<u>Notes</u> : Pricing may change if axle configuration is changed.		

ENGINE

12EYW	ENGINE, DIESEL {Cummins L9 300} EPA 2024, 300HP @ 2200 RPM, 860 lb-ft Torque @ 1200 RPM, 2200 RPM Governed Speed, 300 Peak HP (Max)	585/-21	564
12VJS	EMISSION, CALENDAR YEAR {Cummins L9} EPA, OBD and GHG Certified for Calendar Year 2024	0/0	0
12XCS	CARB EMISSION WARR COMPLIANCE Does Not Comply with CARB Emission Warranty	0/0	0
12WZE	CARB IDLE COMPLIANCE Does Not Comply with California Clean Air Idle Regulations	0/0	0
12WVH	EPA IDLE COMPLIANCE Low NOx Idle Engine, Complies with EPA Clean Air Regulations; Includes "Certified Clean Idle" Decal on Door	0/0	0
12UWZ	RADIATOR Aluminum, Cross Flow, Front to Back System, 1228 SqIn, with 1167 SqIn Charge Air Cooler, Includes In-Tank Oil Cooler	23/-5	18
	<u>Includes</u> : DEAERATION SYSTEM with Surge Tank : HOSE CLAMPS, RADIATOR HOSES Gates Shrink Band Type; Thermoplastic Coolant Hose Clamps : RADIATOR HOSES Premium, Rubber		
12THT	FAN DRIVE {Horton Drivemaster} Two-Speed Type, Direct Drive, with Residual Torque Device for Disengaged Fan Speed	0/0	0
	<u>Includes</u> : FAN Nylon		
12VAG	AIR CLEANER Single Element, with Integral Snow Valve and In-Cab Control	2/0	2
12703	ANTI-FREEZE Red, Extended Life Coolant; To -40 Degrees F/ -40 Degrees C, Freeze Protection	0/0	0
12849	BLOCK HEATER, ENGINE 120V/1000W, for Cummins ISB/B6.7/ISL/L9 Engines	3/0	3
	<u>Includes</u> : BLOCK HEATER SOCKET Receptacle Type; Mounted below Drivers Door		
12VYP	ENGINE CONTROL, REMOTE MOUNTED No Provision for Remote Mounted Engine Control	0/0	0
12WCG	HOSE CLAMPS, RADIATOR HOSES {R.G. Ray Mini Flex Seal} Coil Spring/"T"-Bolt Constant Torque Type, for Radiator Hoses over 1" I.D.	0/0	0
12926	RADIATOR HOSES Silicone; Molded	0/0	0

<u>Code</u>	<u>Description</u>	<u>F/R Wt</u> (lbs)	<u>Tot Wt</u> (lbs)
12VXT	THROTTLE, HAND CONTROL Engine Speed Control; Electronic, Stationary, Variable Speed; Mounted on Steering Wheel	0/0	0
TRANSMISSION			
13BDR	TRANSMISSION, AUTOMATIC {Allison 3500 RDS} 6th Generation Controls, Wide Ratio, 6-Speed with Double Overdrive, with PTO Provision, Less Retarder, Includes Oil Level Sensor, with 80,000-lb GVW and GCW Max, On/Off Highway	216/67	283
13WYH	TRANSMISSION TCM LOCATION Located Inside Cab	0/0	0
13WUC	ALLISON SPARE INPUT/OUTPUT for Rugged Duty Series (RDS) and Regional Haul Series (RHS), General Purpose Trucks, Construction, Package Number 223	0/0	0
13WVV	NEUTRAL AT STOP Allison Transmission Shifts to Neutral When Service Brake is Depressed and Vehicle is at Stop; Remains in Neutral Until Service Brake is Released	0/0	0
13XAL	PTO LOCATION Customer Intends to Install PTO at Left Side of Transmission	0/0	0
13WYU	SHIFT CONTROL PARAMETERS {Allison} 3000 or 4000 Series Transmissions, Performance Programming	0/0	0
13WLP	TRANSMISSION OIL Synthetic; 29 thru 42 Pints	0/0	0
13WET	TRANSMISSION SHIFT CONTROL Column Mounted Stalk Shifter, Not for Use with Allison 1000 & 2000 Series Transmission	1/0	1
CLUTCH			
11001	CLUTCH Omit Item (Clutch & Control)	0/0	0
REAR AXLES, SUSPENSIONS			
14ASA	AXLE, REAR, SINGLE {Meritor RS-26-185} Single Reduction, 26,000-lb Capacity, Driver Controlled Locking Differential, R Wheel Ends . Gear Ratio: 5.86 <u>Notes</u> : Axle Lead Time is 60 Days	0/290	290
14VAJ	SUSPENSION, REAR, SINGLE 31,000-lb Capacity, Vari-Rate Springs, with 4500-lb Capacity Auxiliary Rubber Springs	0/132	132
14WMH	AXLE, REAR, LUBE {EmGard FE-75W-90} Synthetic Oil; 40 thru 49.99 Pints	0/0	0
14WAP	SHOCK ABSORBERS, REAR (2)	0/45	45
FRONT AXLES			
2ARU	AXLE, FRONT NON-DRIVING {Meritor MFS-16-143A} Wide Track, I-Beam Type, 16,000-lb Capacity	148/0	148
FRONT SUSPENSIONS			
3ADE	SUSPENSION, FRONT, SPRING Parabolic Taper Leaf, Shackle Type, 16,000-lb Capacity, with Shock Absorbers	44/0	44

<u>Code</u>	<u>Description</u>	<u>F/R Wt</u> (lbs)	<u>Tot Wt</u> (lbs)
CABS, COWLS, BODIES			
16030	CAB Conventional, Day Cab	0/0	0
16ZBT	ACCESS, CAB Steel, Driver & Passenger Sides, Two Steps per Door, for use with Day Cab and Extended Cab	0/0	0
16BAM	AIR CONDITIONER with Integral Heater and Defroster	0/0	0
16WBY	ARM REST, RIGHT, DRIVER SEAT	3/0	3
16VKB	CAB INTERIOR TRIM Classic, for Day Cab	0/0	0
	<u>Includes</u> : CONSOLE, OVERHEAD Molded Plastic with Dual Storage Pockets, Retainer Nets and CB Radio Pocket; Located Above Driver and Passenger : DOME LIGHT, CAB Door Activated and Push On-Off at Light Lens, Timed Theater Dimming, Integral to Overhead Console, Center Mounted : SUN VISOR (2) Padded Vinyl; 2 Moveable (Front-to-Side) Primary Visors, Driver Side with Toll Ticket Strap		
16XCW	CAB, INTERIOR TRIM, CLOSEOUT Under IP, Driver Side	0/0	0
16WSK	CAB REAR SUSPENSION Air Bag Type	0/0	0
16WEE	CAB SOUND INSULATION Includes Dash Insulator and Engine Cover Insulator	12/0	12
16ZPH	FLOOR, COATING LINE-X, Applied to Interior Cab Floor	0/0	0
16WLS	FRESH AIR FILTER Attached to Air Intake Cover on Cowl Tray in Front of Windshield Under Hood	0/0	0
16GED	GAUGE CLUSTER Base Level; English with English Electronic Speedometer	0/0	0
	<u>Includes</u> : GAUGE CLUSTER DISPLAY: Base Level (3" Monochromatic Display), Premium Level (5" LCD Color Display); Odometer, Voltmeter, Diagnostic Messages, Gear Indicator, Trip Odometer, Total Engine Hours, Trip Hours, MPG, Distance to Empty/Refill for : GAUGE CLUSTER Speedometer, Tachometer, Engine Coolant Temp, Fuel Gauge, DEF Gauge, Oil Pressure Gauge, Primary and Secondary Air Pressure : WARNING SYSTEM Low Fuel, Low DEF, Low Oil Pressure, High Engine Coolant Temp, Low Battery Voltage (Visual and Audible), Low Air Pressure (Primary and Secondary)		
16HGH	GAUGE, OIL TEMP, AUTO TRANS for Allison Transmission	1/0	1
16HCS	GAUGE, TEMPERATURE, AMBIENT Sensor Wiring with Display Unit Mounted in Cluster	0/0	0
16SGH	GRAB HANDLE, EXTERIOR (2) Chrome, for Cab Entry, (1) Towel Bar Type, with Anti-Slip Rubber Inserts Mounted Left Side at B-Pillar, (1) Towel Bar Type Mounted Right Side on Vertical Exhaust	4/2	6
16GHU	GRAB HANDLE, CAB INTERIOR (2) Safety Yellow	0/0	0
16XJP	INSTRUMENT PANEL Wing Panel	0/0	0
16HKT	IP CLUSTER DISPLAY On Board Diagnostics Display of Fault Codes in Gauge Cluster	0/0	0

Code	Description	F/R Wt Tot Wt	
		(lbs)	(lbs)
16SNS	MIRRORS (2) Aero Pedestal, Power Adjust, Heated, Black Heads and Arms, 6.5" x 14" Flat Glass, Includes 6.5" x 6" Convex Mirrors, for 102" Load Width <u>Notes</u> : Mirror Dimensions are Rounded to the Nearest 0.5"	0/0	0
16VLV	MONITOR, TIRE PRESSURE Omit	-10/-1	-11
16VCC	SEAT BELT All Orange; 1 to 3	0/0	0
16JYX	SEAT, DRIVER {National 2000} Air Suspension, High Back with Integral Head Rest, Cloth, Isolated, 1 Chamber Lumbar, 2 Position Front Cushion Adjustment, -3 to +14 Degree Seat Back Angle Adjustment, Dual Shocks	1/0	1
16SMX	SEAT, PASSENGER {Seats, Inc.} Non Suspension, High Back, Fixed Back, Integral Headrest, Cloth, for use with Batteries in Cab	91/38	129
16WJU	WINDOW, POWER (2) and Power Door Locks, Left and Right Doors, Includes Express Down Feature	0/0	0
FRAMES			
1CAJ	FRAME RAILS Heat Treated Alloy Steel (120,000 PSI Yield); 10.866" x 3.622" x 0.437" (276.0mm x 92.0mm x 11.1mm); 456.0" (11582mm) Maximum OAL	146/361	507
1LLA	BUMPER, FRONT Swept Back, Steel, Heavy Duty	0/0	0
1570	TOW HOOK, FRONT (2) Frame Mounted	8/0	8
1WGR	WHEELBASE RANGE 138" (350cm) Through and Including 187" (475cm)	74/-74	0
BRAKES			
4091	BRAKE SYSTEM, AIR Dual System for Straight Truck Applications <u>Includes</u> : BRAKE LINES Color and Size Coded Nylon : DRAIN VALVE Twist-Type : GAUGE, AIR PRESSURE (2) Air 1 and Air 2 Gauges; Located in Instrument Cluster : PARKING BRAKE CONTROL Yellow Knob, Located on Instrument Panel : PARKING BRAKE VALVE For Truck : QUICK RELEASE VALVE On Rear Axle for Spring Brake Release: 1 for 4x2, 2 for 6x4 : SPRING BRAKE MODULATOR VALVE R-7 for 4x2, SR-7 with relay valve for 6x4/8x6	0/0	0
4AZA	AIR BRAKE ABS {Bendix AntiLock Brake System} 4-Channel (4 Sensor/4 Modulator) Full Vehicle Wheel Control System	0/0	0
4GBM	BRAKE, PARKING Manual Push-Pull Pneumatic Parking Brake	1/0	1
4XDT	BRAKES, FRONT {Meritor 16.5X6 Q-PLUS CAST} Air S-Cam Type, Cast Spider, Fabricated Shoe, Double Anchor Pin, Size 16.5" X 6", 23,000-lb Capacity	33/0	33
4EXV	BRAKE CHAMBERS, FRONT AXLE {Bendix} 24 SqIn	4/0	4
4LAG	SLACK ADJUSTERS, FRONT {Gunite} Automatic	14/0	14
4WBX	DUST SHIELDS, FRONT BRAKE for Air Cam Brakes	10/0	10

<u>Code</u>	<u>Description</u>	<u>F/R Wt Tot Wt</u>	
		(lbs)	(lbs)
4XCY	BRAKES, REAR {Meritor 16.5X7 Q-PLUS HD} Air S-Cam Type, Cast Spider, Heavy Duty Fabricated Shoe, Double Anchor Pin, Size 16.5" X 7", 26,000-lb Capacity per Axle	0/85	85
4EXU	BRAKE CHAMBERS, REAR AXLE {Bendix EverSure} 30/30 SqIn Spring Brake	0/7	7
4LGG	SLACK ADJUSTERS, REAR {Gunitex} Automatic	0/14	14
4WDM	DUST SHIELDS, REAR BRAKE for Air Cam Brakes	0/10	10
4LGR	SLACK ADJUSTER PINS Stainless Steel Slack Adjuster Pins/Cotter Pins on Front and Rear	0/0	0
4SPA	AIR COMPRESSOR {Cummins} 18.7 CFM	0/0	0
4EBD	AIR DRYER {Wabco System Saver 1200} with Heater	7/4	11
4VKC	AIR DRYER LOCATION Mounted Inside Left Rail, Back of Cab	13/8	21
4VCL	AIR TANK LOCATION (2) Mounted Back of Cab, Outside Right Rail, with Ground Clearance	0/40	40
4WDA	DRAIN VALVE (3) Petcocks, for Air Tanks	0/0	0
STEERING			
5PSL	STEERING GEAR {Sheppard M110} Power	44/-3	41
5708	STEERING COLUMN Tilting	14/1	15
5CAW	STEERING WHEEL 4-Spoke; 18" Dia., Black	0/0	0
DRIVELINES			
6DGG	DRIVELINE SYSTEM {Dana Spicer} 1710, for 4x2/6x2	6/22	28
EXHAUST SYSTEMS			
7BMB	EXHAUST SYSTEM Horizontal Aftertreatment System, Frame Mounted Right Side Under Cab, for Single Vertical Tail Pipe, Frame Mounted Right Side Back of Cab, for Improved Ground Clearance	127/38	165
7BEV	AFTERTREATMENT COVER Steel, Black	10/3	13
7WDM	EXHAUST HEIGHT 10'	16/12	28
7WDN	MUFFLER/TAIL PIPE GUARD (1) Aluminum	9/7	16
7WZY	SWITCH, FOR EXHAUST 2 Position, Lighted & Latching, On/Off Type, Mounted in IP, Inhibits Diesel Particulate Filter Regeneration as Long as Switch is in On Position	2/0	2
7WAZ	TAIL PIPE (1) Turnback Type	6/4	10
ELECTRICAL SYSTEMS			
8000	ELECTRICAL SYSTEM 12-Volt, Standard Equipment	0/0	0
	<u>Includes</u> : DATA LINK CONNECTOR For Vehicle Programming and Diagnostics In Cab		

<u>Code</u>	<u>Description</u>	<u>F/R Wt Tot Wt</u>	
		(lbs)	(lbs)
	: HAZARD SWITCH Push On/Push Off, Located on Instrument Panel to Right of Steering Wheel : HEADLIGHT DIMMER SWITCH Integral with Turn Signal Lever : PARKING LIGHT Integral with Front Turn Signal and Rear Tail Light : STARTER SWITCH Electric, Key Operated : STOP, TURN, TAIL & B/U LIGHTS Dual, Rear, Combination with Reflector : TURN SIGNAL SWITCH Self-Cancelling for Trucks, Manual Cancelling for Tractors, with Lane Change Feature : WINDSHIELD WIPER SWITCH 2-Speed with Wash and Intermittent Feature (5 Pre-Set Delays), Integral with Turn Signal Lever : WINDSHIELD WIPERS Single Motor, Electric, Cowl Mounted : WIRING, CHASSIS Color Coded and Continuously Numbered		
8GXD	ALTERNATOR {Leece-Neville AVI160P2013} Brush Type, 12 Volt, 160 Amp Capacity, Pad Mount, with Remote Sense	0/0	0
8RPR	ANTENNA for Increased Roof Clearance Applications	1/0	1
8XHZ	BATTERY BOX Steel, 2-3 Battery Capacity, Mounted Inside the Cab, Under Passenger Seat, with High Ground Clearance Exhaust	0/0	0
8MMZ	BATTERY SYSTEM {Fleetrite AGM-GP31} Maintenance-Free, (3) AGM 12-Volt 2475CCA Total, Top Threaded Stud	49/57	106
8HAB	BODY BUILDER WIRING Back of Day Cab at Left Frame or Under Sleeper, Extended or Crew Cab at Left Frame; Includes Sealed Connectors for Tail/Amber Turn/Marker/ Backup/Accessory Power/Ground and Sealed Connector for Stop/Turn	2/0	2
8XAH	CIRCUIT BREAKERS Manual-Reset (Main Panel) SAE Type III with Trip Indicators, Replaces All Fuses	0/0	0
8WPH	CLEARANCE/MARKER LIGHTS (5) {Truck Lite} Amber LED Lights, Flush Mounted on Cab or Sunshade	0/0	0
8HAH	ELECTRIC TRAILER BRAKE/LIGHTS Accommodation Package to Rear of Frame; for Combined Trailer Stop, Tail, Turn, Marker Light Circuits; Includes Electric Trailer Brake Accommodation Package with Cab Connections for Mounting Customer Installed Electric Brake Unit, Less Trailer Socket	0/2	2
8XNY	HEADLIGHTS Halogen	0/0	0
8XHN	HORN, AIR Single Trumpet, Black, with Lanyard Pull Cord	3/0	3
8541	HORN, ELECTRIC (2) Disc Style	1/0	1
8WWJ	INDICATOR, LOW COOLANT LEVEL with Audible Alarm	0/0	0
8XPK	POWER SOURCE, ADDITIONAL Auxiliary Power Outlet (APO) with USB-A Port and USB-C Port, Located in the Instrument Panel	0/0	0
8RPS	RADIO AM/FM/WB/Clock/Bluetooth/USB Input/Auxiliary Input	3/0	3
8RPB	RADIO, AUXILIARY CONTROLS Mounted in Steering Wheel, Radio Function Control Switch, Includes Volume Up/Down, Mute, Forward/Back and Bluetooth Answer/Disconnect	9/1	10
8RMV	SPEAKERS (2) 6.5" Dual Cone Mounted in Doors	5/0	5
8WXG	STARTING MOTOR {Mitsubishi Electric Automotive America 105P} 12-Volt, with Soft-Start	10/0	10

<u>Code</u>	<u>Description</u>	<u>F/R Wt</u> (lbs)	<u>Tot Wt</u> (lbs)
8XGT	TURN SIGNALS, FRONT Includes LED Side Turn Lights Mounted on Fender	0/0	0
FRONT END			
9WBC	FRONT END Tilting, Fiberglass, with Three Piece Construction, for WorkStar/HV	0/0	0
9WAC	BUG SCREEN Mounted Behind Grille	5/0	5
9HBM	GRILLE Stationary, Chrome	0/0	0
9HBN	INSULATION, SPLASH PANELS for Sound Abatement	2/0	2
9HAN	INSULATION, UNDER HOOD for Sound Abatement	10/0	10
9AAB	LOGOS EXTERIOR Model Badges	0/0	0
9AAE	LOGOS EXTERIOR, ENGINE Badges	0/0	0
SPEEDOMETER, TOOLS, MISC			
10AGB	COMMUNICATIONS MODULE Telematics Device with Over the Air Programming; Includes Five Year Data Plan and International 360	1/0	1
10XAN	FIRE EXTINGUISHER 5 lb Class A B C	8/2	10
10XAP	FIRE EXTINGUISHER BRACKET Mounted Left Side Driver Seat	1/0	1
10WBS	KEYS - ALL ALIKE, ADDITIONAL 2 Keys	0/0	0
10WKS	KEYS - ALL ALIKE, ID I-1518 Compatible with Z-026	0/0	0
10060	PAINT SCHEMATIC, PT-1 Single Color, Design 100 <u>Includes</u> : PAINT SCHEMATIC ID LETTERS "WL"	0/0	0
10761	PAINT TYPE Base Coat/Clear Coat, 1-2 Tone	0/0	0
10SLV	PROMOTIONAL PACKAGE Government Silver Package	0/0	0
10WCY	SAFETY TRIANGLES	6/0	6
FUEL TANKS			
15SGJ	FUEL TANK Top Draw, Non-Polished Aluminum, D-Style, 16" Tank Depth, 50 US Gal (189L), Mounted Left Side, Under Cab	23/3	26
15WDG	DEF TANK 7 US Gal (26L) Capacity, Frame Mounted Outside Left Rail, Under Cab	0/0	0
15LNR	FUEL/WATER SEPARATOR {Racor 400 Series} with Primer Pump, Includes Water-in-Fuel Sensor, Mounted on Engine	0/0	0
WHEELS, TIRES - FRONT			
27DJM	WHEELS, FRONT {Maxion 91541} DISC; 22.5x8.25 Rims, Painted Steel, 2-Hand Hole, 10-Stud, 285.75mm BC, Hub-Piloted, Flanged Nut, with Steel Hubs	-12/0	-12
7382135439	(2) TIRE, FRONT 11R22.5 Load Range H HSR 3 (CONTINENTAL), 494 rev/mile, 75 MPH, All-Position	4/0	4

<u>Code</u>	<u>Description</u>	<u>F/R Wt</u> (lbs)	<u>Tot Wt</u> (lbs)
WHEELS, TIRES - REAR			
28DJM	WHEELS, REAR {Maxion 91541} DUAL DISC; 22.5x8.25 Rims, Painted Steel, 2-Hand Hole, 10-Stud, 285.75mm BC, Hub-Piloted, Flanged Nut, with Steel Hubs	0/-24	-24
7382135444	(4) TIRE, REAR 11R22.5 Load Range H HDR2+ (CONTINENTAL), 491 rev/mile, 75 MPH, Drive	0/20	20
WHEELS MISC OPTIONS			
29PAR	PAINT IDENTITY, FRONT WHEELS Disc Front Wheels; with Vendor Applied White Powder Coat Paint	0/0	0
29PAS	PAINT IDENTITY, REAR WHEELS Disc Rear Wheels; with Vendor Applied White Powder Coat Paint	0/0	0
29WLK	WHEEL BEARING, FRONT, LUBE {EmGard FE-75W-90} Synthetic Oil	0/0	0
BODY INTEGRATION			
60AAG	BDY INTG, REMOTE POWER MODULE Mounted Inside Cab Behind Driver Seat, Up to 6 Outputs & 6 Inputs, Max 20 amp per Channel, Max 80 amp Total; Includes 1 Switch Pack with Latched Switches	0/0	0
60AJK	BDY INTG, INDICATOR LIGHTS (2) 1 for Body Up, 1 for Gate Open, Includes Audible Alarm, Programmable Mode for Various Switch Actions. (Requires 2 Remote Power Module Inputs)	0/0	0
60ABE	BDY INTG, PTO ACCOMMODATION for Electric over Hydraulic PTO, Does Not Include Solenoids, with Latched Switch Mounted on Dash Includes Audible Alarm and Indicator Light in Gauge Cluster (Requires 1 Remote Power Module input & 1 output)	0/0	0
	Cab schematic 100WL Location 1: 2303, Red (Std)		
	Chassis schematic N/A		
	Services Section:		
WARRANTY			
40128	WARRANTY Standard for HV507, HV50B, HV607 Models, Effective with Vehicles Built July 1, 2017 or Later, CTS-2025A	0/0	0
	Total Component Weight:	7906/4685	12591
		(lbs)	(lbs)
		(lbs)	(lbs)
	MI Deal Fee Spec 3958-0160D Option B	0/0	0
	Total Goods Purchased:	0/0	0

The weight calculations included in this proposal are an estimate of future vehicle weight. The actual weight as manufactured may be different from the estimated weight. Navistar, Inc. shall not be liable for any consequences resulting from any differences between the estimated weight of a vehicle and the actual weight.

(0012EYW)
ATTACHMENTS: 0060ABE 0012VXT 0012THT 0007WZY

<u>Parameter</u>	<u>Value</u>	<u>UOM</u>
Max Accelerator Vehicle Speed	71	MPH
Road Speed Governor Upper Droop	3	MPH
Road Speed Governor Lower Droop	0.0	MPH
Driver Initiated Override (DIO)	N, DISABLE FEATURE OR FUNCTION	N/A
DIO Maximum Road Speed Delta	3	MPH
DIO Maximum Distance	100	MILES
Max Engine Speed No Veh Speed Sensr	2184	RPM
LBSC Enable	N, DISABLE FEATURE OR FUNCTION	N/A
LBSC - Engine Speed Breakpoint	1800	RPM
Gear Down Protection Enable	N, DISABLE FEATURE OR FUNCTION	N/A
GDP - Heavy Load Vehicle Speed	62	MPH
GDP - Light Load Vehicle Speed	57	MPH
Driver Reward Enable	N, DISABLE FEATURE OR FUNCTION	N/A
Driver Reward Mode	0, ROAD SPEED GOVERNOR	N/A
Fuel Economy - Expected Level	7.00	MPG
Fuel Economy - Good Level	7.25	MPG
Fuel Economy - Best Level	7.50	MPG
% Idle Time - Expected Level	30	%
% Idle Time - Good Level	20	%
% Idle Time - Best Level	10	%
Speed Reward - Expected Level	0	MPH
Speed Reward - Good Level	0	MPH
Speed Reward - Best Level	0	MPH
Speed Reward - Penalty Level	0	MPH
Idle Speed Adjustment Enable	Y, ENABLE FEATURE OR FUNCTION	N/A
Low Idle Speed	750	RPM
Idle Shutdown Enable	N, DISABLE FEATURE OR FUNCTION	N/A
ISD Time Before Shutdown	15.0	MIN
ISD Percent Engine Loading	100	%
ISD In PTO	N, DISABLE FEATURE OR FUNCTION	N/A
ISD Manual Override	N, DISABLE FEATURE OR FUNCTION	N/A
ISD With Parking Brake Set	N, DISABLE FEATURE OR FUNCTION	N/A
ISD Ambient Temperature Override	N, DISABLE FEATURE OR FUNCTION	N/A
ISD Cold Ambient Air Temperature	30	F
ISD Intermediate Ambient Air Temp	40	F
ISD Hot Ambient Air Temperature	81	F
ISD Manual Override Inhibit Zone En	N, DISABLE FEATURE OR FUNCTION	N/A
ISD Hot Ambient Automatic Override	Y	N/A
ISD Engine Coolant Temp Threshold	53	F
Cruise Control Enable	Y, ENABLE FEATURE OR FUNCTION	N/A
CC Maximum Vehicle Speed	71	MPH
CC Save Set Speed	N, DISABLE FEATURE OR FUNCTION	N/A
CC Upper Droop	3.0	MPH
CC Lower Droop	0.0	MPH
CC Auto Resume	N, DISABLE FEATURE OR FUNCTION	N/A
CC Engine Brake Swtch Bypass Enable	N, DISABLE FEATURE OR FUNCTION	N/A
Engine Fan Min On Time For AC	30	SEC
Remote Accelerator Enable	N, DISABLE FEATURE OR FUNCTION	N/A
Remote Accelerator Mode	1, REMOTE ACCELERATOR PEDAL OR LEVER WITH TRANS VERIFICATION	N/A
PTO Enable	Y, ENABLE FEATURE OR FUNCTION	N/A
PTO In Cab Mode	Y, ENABLE FEATURE OR FUNCTION	N/A
Remote PTO Enable	N, DISABLE FEATURE OR FUNCTION	N/A
Remote Station PTO Enable	N, DISABLE FEATURE OR FUNCTION	N/A
PTO Max Engine Speed	1500	RPM

PTO Min Engine Speed	500	RPM
PTO Maximum Engine Load	1199	LB-FT
PTO Max Vehicle Speed	2	MPH
PTO Accelerator Override	N, DISABLE FEATURE OR FUNCTION	N/A
PTO Accel Override Max Engine Speed	1500	RPM
PTO Clutch Override	N, DISABLE FEATURE OR FUNCTION	N/A
PTO Service Brake Override	Y, ENABLE FEATURE OR FUNCTION	N/A
PTO Parking Brake Interlock Mode	1, PTO PRK BRK INT TYPE SET TO CAB ONLY	N/A
PTO Transmission Neutral Interlock	Y, ENABLE FEATURE OR FUNCTION	N/A
PTO Eng Spd Limit w/VSS Limit	N, DISABLE FEATURE OR FUNCTION	N/A
PTO Ignore Vehicle Speed Sensor	N, DISABLE FEATURE OR FUNCTION	N/A
PTO Resume Switch Speed	700	RPM
PTO Set Switch Speed	1500	RPM
PTO Additional Switch Speed	700	RPM
PTO Ramp Rate	100	RPM/SEC
Remote PTO Number of Speed Settings	1	N/A
Remote PTO Speed Setting 1	1000	RPM
Remote PTO Speed Setting 2	1200	RPM
Remote PTO Speed Setting 3	1400	RPM
Remote PTO Speed Setting 4	1400	RPM
Remote PTO Speed Setting 5	1500	RPM
Remote Station PTO Resume Sw Spd	1000	RPM
Remote Station PTO Set Switch Speed	1500	RPM
Remote Station PTO Addition Sw Spd	1500	RPM
Transmission Driven PTO	N, DISABLE FEATURE OR FUNCTION	N/A
Transmission Driven PTO Type	0, ENGINE DRIVEN STEADY LOAD	N/A
Powertrain Protection Enable	N, DISABLE FEATURE OR FUNCTION	N/A
Max Torque Allow By Axle/Driveshaft	23602	LB-FT
Max Torque in Top Gear Range	2995	LB-FT
Max Torque in Int. Gear Range	2995	LB-FT
Max Torque in Low Gear Range	2995	LB-FT
Max Torque w/o Vehicle Speed	1475	LB-FT
Lowest Gear of Top Gear Range	2.00	N/A
Lowest Gear of Int. Gear Range	3.00	N/A
Lowest Gear of Low Gear Range	6.00	N/A
Engine Protection Shutdown	Y, ENABLE FEATURE OR FUNCTION	N/A
Engine Protection Restart Inhibit	Y, ENABLE FEATURE OR FUNCTION	N/A
Engine Prot Coolant Level Shutdown	N, DISABLE FEATURE OR FUNCTION	N/A
Sudden Veh Speed Decel Threshold	6.96	MPH
Trip Information Vehicle Ovrsped1	78	MPH
Trip Information Vehicle Ovrsped2	80	MPH
Veh Speed Sensor Anti Tamper Level	1, HIGH LEVEL	N/A
Maintenance Monitor Enable	N, DISABLE FEATURE OR FUNCTION	N/A
Maintenance Monitor Operating Mode	0, MAINTENANCE MONITOR AUTOMATIC MODE OF OPERATION	N/A
Maintenance Monitor Alert Percent	90	%
Maintenance Monitor Distance	15000	MILES
Maintenance Monitor Fuel	2000	GALLONS
Maintenance Monitor Time	500	HOURS
Maintenance Monitor Interval Factor	1.00	N/A
Master Password	000000	N/A
Adjustment Password	000000	N/A
Reset Password	000000	N/A

These Electronic Parameters have not been finalized

<u>Description</u>	<u>(US DOLLAR)</u>	<u>Price</u>
Total Factory List Price Including Options:		\$154,727.00
Total Goods Purchased:		\$826.03
Total Preparation And Delivery:		\$1,760.00
Total Freight:		\$3,100.00
Total Factory List Price Including Freight:		\$160,413.03
Less Customer Allowance:		(\$64,872.02)
Total Vehicle Price:		\$95,541.01
Total Sale Price:		\$95,541.01
Total Per Vehicle Sales Price:		\$95,541.01
Total Net Sales Excluding Taxes:		\$95,541.01
Total License, Title:		\$15.00
Net Sales Price:		\$95,556.01

Note Additional Surcharges may be added by the Manufacturer

Payment for the chassis is due upon delivery of the cab/chassis to the end user or body company; which ever occurs first. If payment is not received in a timely manner additional floorplan(interest) costs may be charged to the end-user customer.

Please make all purchase orders and checks payable to:
Tri-County International Trucks, Inc.
5701 Wyoming Ave.
Dearborn, MI 48126

Please review this proposal very carefully. Your signature below indicates that you accept the specifications and payment terms, contained herein as written and that you are able to approve said specifications for order and payment terms. Please include this proposal number on all correspondence and purchase orders.

Approved by Seller:

Accepted by Purchaser:

Official Title and Date

Firm or Business Name

Authorized Signature

Authorized Signature and Date

TRI COUNTY INTL TRUCKS
3001 E HIGH ST
JACKSON MI 49203
(517)783-2721

This proposal is not binding upon the seller without Seller's Authorized Signature

Official Title and Date

The TOPS FET calculation is an estimate for reference purposes only. The seller or retailer is responsible for calculating and reporting/paying appropriate FET to the IRS.

The limited warranties applicable to the vehicles described herein are Navistar, Inc.'s standard printed warranties which are incorporated herein by reference and to which you have been provided a copy and hereby agree to their terms and conditions.



Moving Forward Working Together

TO: Village President and Council
FROM: Deboria L. Powell, Village Manager
DATE: April 29, 2024
SUBJECT: Approval of Purchase of Salt Truck Equipment

With the ordering of the 2025 International HV607 chassis for use as salt/plow truck for the DPW, we will need to upfit the truck with equipment. The items that would need to be added to the truck are a dump box with tarp, 12' underbody scraper, salt spreader, hydraulic system, and hazard light system.

By purchasing the equipment now, we lock in our cost at \$81,500.00. This equipment would be purchased now, and the vendor would hold all equipment in anticipation of mounting to the truck chassis. Once the truck chassis arrives, International will deliver to Shults Equipment LLC for the equipment to be installed onto the chassis. The quote includes the price for equipment installed on one unit.

Staff recommends the purchase of this equipment to be available at the time of delivery for the 2025 International HV607.

We have funds available and budgeted in 651-001-970 in our Capital Improvement Plan.

MOTION: Approve the purchase of snow and salt equipment for use on the ordered 2025 International HV607 chassis dump truck for the DPW, from Shults Equipment LLC, in the amount of \$81,500.00.

In accordance with Federal Law and U.S. Department of Agriculture policy, this institution is prohibited from discriminating on the basis of race, color, national origin, sex, age or disability.

This institution is an equal opportunity provider and employer.

6506 Main St., P.O. Box 123, Cass City, MI 48726 * 989-872-2911 * Fax 989-872-4855 *
TTY 989-872-4742 or e-mail: casscity.org

SHULTS EQUIPMENT, LLC.

P.O. Box 127
Ithaca, MI 48847
PH: (989) 875-4570 FAX: (989) 875-2922

April 2, 2024

To: City of Cass City
Attn: Jeremy Russell

We would like to provide pricing on equipment for a new single axle truck as follows:

Galion model 403U, 10' x 8' dump body

Constructed of 201 #4 polished 7 gauge stainless steel
32" side height
40" front height
40" rear tailgate height
1/4" AR450 floor
6" floor to side radius
2 panel double acting tailgate
Air trip tailgate with 3-1/2" cylinder
All tailgate hardware to be stainless steel
Dirt shedding boxed top rails
Horizontal side bracing
4" structural channel cross members on 12" centers
24" cab shield constructed of 201 #4 polished stainless steel
Stainless steel ladder installed on driver's side over rear drive tires
Stainless steel shovel holder installed on front bulkhead
Stainless steel mudflaps ahead of rear duals
1/2" thick anti-sail mud flaps behind rear tires
Galion hoist and full underbody subframe
Greaseable and removable rear hinge assembly
Body up proximity switch with warning light in cab

Roll-Rite 6300 Electric Tarp System

Aluminum tarp housing recessed into cab shield
3-spring pivot arms
30 degree offsets in arms
14' premium mesh tarp
Heavy Duty resettable circuit breaker
In-cab controls

Michigan TMS189-12' Underbody Scraper

Severe duty
Extra thick solid mainframe
1" thick solid circle
1" x 20" x 12' moldboard with integral step
Piloted and sealed oversized center pin

Free-floating 2" reverse cylinder pins
2" Socatri piston rods on all cylinders
1" thick circle hangers
Remote grease line for center pin
Cross over cushion valve relief

Salt Spreader:

Swenson SAGS
Stainless Steel
6" hard surfaced auger
Discharge 16" in from driver's side
18" poly spinner disc
Stainless steel quick disconnects for easy removal
of spreader and spinner in the off-season

Certified Power Hydraulic Control System

Chelsea Hot-Shift transmission mounted PTO
Danfoss Hydraulic valve in stainless steel enclosure, with
double acting air actuated section for:
Hoist up/down (26 GPM)
Scraper up/down (17.6 GPM)
Scraper left/right (17.6 GPM)
Electric actuated work sections for:
Auger (17 GPM)
Spinner (7 GPM)
Main relief in valve set to 2,500 PSI
Adjustable down pressure reliefs for hoist and scraper
Air control handles will be installed in a custom built
control stand with locking feature on hoist handle
Air pressure protection valve installed to protect
truck from losing air pressure in the event of an airline
failure
Parker Tough Cover hydraulic hoses

Combination Fuel & Hydraulic Oil Tanks

Fuel Tank:
Utilize factory 50 gallon aluminum fuel tank under
driver's side of cab

Hydraulic Tank:
29 gallon capacity
Manufactured of 10 gauge carbon steel
Zinga style in-tank return filter assembly
3" suction port
Suction strainer
2" Full flow ball valve on suction line
5" Sight/temp. gauge
Ports for low oil sender and case drain
Magnetic drain plug
Painted black with PPG polyurethane paint

Rear Hitch

2.5" receiver tube
D-rings for chains
Re-install chassis supplied trailer plug

Light System

Whelen Responder LED mini-light bar mounted to fabricated bracket stainless steel bracket on center of tarp housing for 360 degree visibility
Stainless steel brush guard to protect mini-lightbar
(2)Whelen 500 series 6" oval amber/green LED strobes mounted in rear corner posts
(4)Maxxima hybrid 6" oval red LED s/t/t lights with back up light mounted in rear corner posts
(2) LED heated scraper work lights
(2) LED heated spreader work lights
(3) ¾" round marker lights in rear hitch area
Electric brake controller installed
Back-up Alarm
Body-up up proximity switch with light in cab
Betts junction boxes, one in cab and one on outside of box at rear

Other Installation Notes:

Heavy duty zips ties will be used a minimum of every 6" when securing hose and wires
Parker 387 Tough cover hydraulic hose (3,000 psi) will be used for all pressure lines
Abrasive resistant guards will be used wherever hose and electrical lines cross a steel component
Abrasive resistant loom will be installed on all electric wires

Total price for equipment installed on one (1) unit: \$ 81,500.00

Note: For installation of above equipment, truck must have:

- 102" CA measurement
- 24" ground clearance for body & under-truck scraper.
- Batteries located under passenger's seat in cab
- bucket seats in cab for requested location of controls, etc.
- exhaust components located in such a way to allow for installation of under-truck scraper.
- 6 pack auxiliary electrical switches, fused.
- Trailer plug and wiring run to rear of chassis
- Electric brake controller wires in dash

Prices firm for 30 days.

F.O.B.: Ithaca, MI.

Thank you for the opportunity to be of service.

Shults Equipment, LLC.

Joe Vernon

Q.CASSCITY



TO: Village President and Council
FROM: Deboria L. Powell, Village Manager
DATE: April 29, 2024
RE: Approve Purchase of Pool Chemicals for 2024 season

An estimate has been prepared from B&B Pool Service to replenish our supply of pool chemicals for the 2024 Helen Stevens Memorial Pool season.

The pool had a small amount of both Pulsar briquettes and PH Down left at the end of the 2023 season, and we are requesting to order (40) 50# gallon pails of the chlorine briquettes and (15) pails of the PH Down, which should cover a majority of the 2024 season.

The pool is tentatively scheduled to open on Saturday, May 25, 2024.

MOTION: Approve purchase from B&B Pool Service, in the amount of \$9,725.00, to replenish chemicals for the municipal pool. Funds are available in #101-752-743.000.

This institution is an equal opportunity provider and employer.

6506 Main St., P.O. Box 123, Cass City, MI 48726 * 989-872-2911 * Fax 989-872-4855 *
TTY 989-872-4742 or e-mail: casscity.org

Melanie Radabaugh

From: Joe Sheridan <Jsheridan@bandbpools.com>
Sent: Monday, April 1, 2024 11:54 AM
To: Melanie Radabaugh
Subject: Chemical Pricing.

Hi Melanie,

Please see chemical pricing below.

Forty (40) 50lb pails Pulsar Briquettes \$200.00 x 40 = \$8,000.00
Fifteen (15) 45lb pails PH Down + 4 \$115.00 x 15 = \$1,725.00

The Village of Cass City is tax exempt. This chemical order would be direct shipped from Pulsar.

Please let me know if you have any questions.

Thank you,

Joe Sheridan
Sales
B&B Pools and Spas
734-427-3242

jsheridan@bandbpools.com

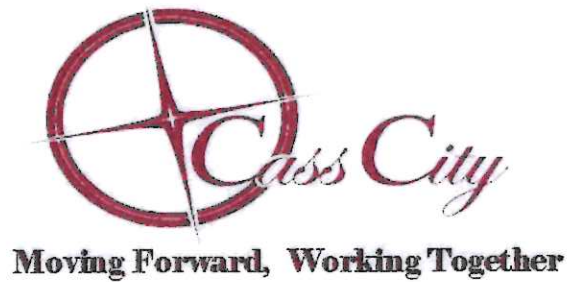

TO: Village President & Council
FROM: Debbie Powell, Village Manager
DATE: April 29, 2024
SUBJECT: Approve pool vacuum purchase from grant funding

The Parks & Recreation committee has recommended that the pool vacuum at the Helen Stevens Memorial Pool be replaced. The current vacuum is large, cumbersome and must be operated by two lifeguards. The purchase of a new pool vacuum would allow us to save on labor costs and increase efficiency in our operations.

A grant application to cover the costs of a new, automatic pool vacuum was submitted to multiple funding sources within the Tuscola County Community Foundation. On April 12, 2024, we received notification that the William and Ruth Janks Fund and the Future Youth Involvement Fund were going to share the costs of this purchase.

After multiple quotes for this unit were researched, we are proposing to order this pool vacuum through Kiefer Aquatics/The Lifeguard Store, with whom we have an established account. The total cost, with shipping, is \$6,749.00.

MOTION: Approve the purchase of a Maytronics Dolphin Wave 120 automatic pool vacuum, from Kiefer Aquatics/The Lifeguard Store, in the amount of \$6,749.00, from line item #101-752-970.000.



Kiefer Aquatics
The Lifeguard Store

903 Morrissey Drive
 Bloomington, IL 61701
 P (309) 451-5858
 F (309) 451-5959

Quote

DATE	Customer #	ESTIMATE
02/01/2024	123086	EST114402



BILL TO
Village of Cass City Nanette Walsh 6506 Main Street Cass City, MI 48726

SHIP TO
Village of Cass City Melanie Radabaugh 6506 Main Street Cass City, MI 48726

Shipped Via:
FEDEX_GROUND

Estimate Prepared by:
mradtke

ITEM	DESCRIPTION	QUANTITY	PRICE EACH	TOTAL
9999359-W120	Maytronics Dolphin Wave 120 Automatic Pool Vacuum	1	\$6,499.00	\$6,499.00
			Subtotal	\$6,499.00
			Freight	\$250.00
			Tax	\$0.00
			Total	\$6,749.00



Excellence. Accountability. Impact.™

Tuscola County

community foundationSM

For good. For ever.®

P.O. Box 534
1100 E Caro Road
Caro, MI 48723

tel 989.673.8223
www.tuscolaccf.org

April 12, 2024

Ms. Melanie Radabaugh, Dir. of Community Development
Village of Cass City
6506 Main St
Cass City, MI 48726

Dear Melanie:

Congratulations! The various grant committees of the **Tuscola County Community Foundation** (TCCF) have met to review the spring 2024 grant applications. TCCF is pleased to announce that your grant application was awarded **\$3,375 from the William and Ruth Janks Fund** to purchase a robotic pool vacuum for the Helen S Stevens Memorial Pool in CC Municipal Park.

Enclosed are two copies of the Grant Agreement, please complete and return one to us, and keep the other for your records.

We ask that you carefully review these documents to ensure your compliance with this grant. Please note that we must have a signed copy of the grant agreement before distribution of your grant check can occur. Your signature confirms your agreement with compliance of these guidelines. Once we receive your signed agreement, we will contact you to arrange a time to present your grant award.

Once again, on behalf of the *William A and Ruth Janks Fund* and the **TCCF**, congratulations to you on this recognition of your organization's charitable mission! Should you have any questions, please feel free to contact me.

Sincerely,

A handwritten signature in black ink, appearing to read "John Hunter".

John Hunter
Executive Director

Encl. Grant Agreement

JH/rd



Excellence. Accountability. Impact.™

Tuscola County

community foundationSM

For good. For ever.®

P.O. Box 534
1100 E Caro Road
Caro, MI 48723

tel 989.673.8223
www.tuscolaccf.org

April 12, 2024

Ms. Melanie Radabaugh, Dir. of Community Development
Village of Cass City
6506 Main St
Cass City, MI 48726

Dear Melanie:

Congratulations! The various grant committees of the **Tuscola County Community Foundation** (TCCF) have met to review the spring 2024 grant applications. TCCF is pleased to announce that your grant application was awarded **\$3,375** from the *FYI Fund* to purchase a robotic pool vacuum for the Helen S Stevens Memorial Pool in CC Municipal Park.

Enclosed are two copies of the Grant Agreement, please complete and return one to us, and keep the other for your records.

We ask that you carefully review these documents to ensure your compliance with this grant. Please note that we must have a signed copy of the grant agreement before distribution of your grant check can occur. Your signature confirms your agreement with compliance of these guidelines. Once we receive your signed agreement, we will contact you to arrange a time to present your grant award.

Once again, on behalf of the *FYI Fund* and the **TCCF**, congratulations to you on this recognition of your organization's charitable mission! Should you have any questions, please feel free to contact me.

Sincerely,

A handwritten signature in black ink, appearing to read "John Hunter", is written over a horizontal line.

John Hunter
Executive Director

Encl. Grant Agreement

JH/rd

**Cass City Downtown Development Authority
Minutes
March 12, 2024**

The Meeting was brought to order at 1:30 pm by Chair Weiler

BOARD MEMBERS PRESENT: Christine Anthony, Tyler Erla, Andrew Klco, David Weiler, Village President Robert Piaskowski

ABSENT: Eric Brown, Misty DeLong, Jon Ligrow, Amy Peters, Cass City Chamber Administrator

VILLAGE STAFF PRESENT: Village Manager Debbie Powell, Director of Community Development Melanie Radabaugh, Administrative Assistant Linda Miller

Motion to approve the minutes from the February 13, meeting by Anthony and supported by Klco. Motion Carried.

Motion to approve the February 29, 2024, Financial Report was made by Erla and supported by Klco. Motion Carried.

Refinance DDA Debt: Eric Brown joined the meeting via phone and explained the two proposals for the refinance/demo loan for the Leach & Pine Street property.

Motion to accept the loan proposal from Thumb Bank & Trust for a loan of \$67,000 for 180 monthly payments, estimated payment \$585/month at a tax-exempt fixed rate of 5.45% for 5 years with rate adjusted based on the weekly average yield on the 10-year Treasury, Loan Fee of \$750 was made by Erla and supported by Anthony. Motion Carried.

Citizen Comments: Barb Kirn mentioned the importance of the Cultural Center Building as it relates to the history of the Village and the importance of restoring this building because of the shared wall with other buildings in the block. She gave an example of a building in Mayville that was demolished and the one building left standing is now unusable due to the damage caused by the demolition of the first building. We do not want this to happen in Cass City. Kirn said the Cass City Cultural Center Historical Group wants to establish a working relationship with the Cass City DDA. They have received their non-profit status and are now able to receive donations. They are in the process of seeking grants from the Pinney Foundation and The Tuscola Community Foundation and other fundraising events to help cover some of the Blight Elimination items that the State Grant will not cover.

Motion for the Cass City DDA to support the Tuscola County Land Bank Authority/Cass City Cultural Center Stabilization Proposal and agrees to the terms of the grant and to fundraising or funding the grant match and providing in-kind services by Erla and supported by Klco. Motion Carried.

Tuscola County EDC Report: No report.

Chamber of Commerce Report: No report. Was mentioned the Freedom Festival Committee recently held its first meeting.

Klco left the meeting at 2:23 pm.

Leach Street Property: Village Manager Powell received several bid quotes for the demolition of the Leach Street Property but due to the lack of a quorum, voting is tabled until the next meeting in April.

MEDC Match on Main Grant: Radabaugh mentioned the Match on Main grant is back in the amount of \$25,000, with a 10% match, to help another business with indoor improvements.

2023 Annual DDA Report: The DDA Annual Report was presented but, due to the lack of a quorum, will need to wait until next month for approval.

By consensus, the meeting was adjourned at 2:26 pm.

Respectfully Submitted,

Linda W. Miller

Administrative Assistant

Cass City Economic Development Corporation (EDC)
Minutes
March 12, 2024

BOARD MEMBERS PRESENT: Christine Anthony, Tyler Erla, David Weiler, Village President
Robert Piaskowski

ABSENT: Eric Brown, Misty DeLong, Andrew Klco, Jon Ligrow, Amy Peters, Cass City Chamber
Administrator

VILLAGE STAFF PRESENT: Village Manager Debbie Powell, Director of Community Development
Melanie Radabaugh, Administrative Assistant Linda Miller.

**Due to the fact that only four members of Cass City Economic Development Corporation (EDC)
were present, out of a full board of nine members, there was no quorum.**

No formal meeting of the Cass City Economic Development Corporation was held.

Next Meeting is scheduled for April 9, 2024.

Respectfully submitted,

Linda W. Miller

Administrative Assistant

Cass City Planning Commission Meeting
Minutes of February 21, 2024

PRESENT: Gary Barnes, Barbara Kirn, Joe Leeson, Eric Oslund,
Dallas Rabideau, Heather Severance, Village President Robert Piaskowski

Village Staff Present: Village Manager Debbie Powell, Nanette Walsh, Clerk/Treasurer

Excused: Colleen Langenburg, Erik Tamlyn

Meeting was called to order at 7:00 pm by Leeson.

Motion by Oslund, supported by Barnes, to approve the minutes of the January 17, 2024 Meeting. Motion carried.

There were no comments during Citizens Comments.

The Ad Hoc Committee reported on their proposed amendments to proposed Ordinance# 200, Permitted Uses for first floor residential use in Community Business Districts. Discussion involved front and rear egress, rear trash and storage for residential use, office/business frontage, and separate, non-public entrance in the front of the building.

By consensus, the Planning Commission recommended that a draft ordinance be presented at the next meeting with the following amendments (in bold type):

“Sec. 46-294 Principal uses permitted subject to special conditions.

(3)Residential Occupancy of First (ground) Floor:

The first (ground) floor of a building may be used for residential, one family occupancy, providing the following conditions are met:

- A) Each first floor dwelling unit shall have a separate, non-public front egress, ~~with an secondary egress in the rear of the Building~~ **or an egress in the side or rear of the building.**
- B) Exterior design and façade materials of the new or redeveloped residential building shall complement or be comparable to the façade plan of surrounding residential/commercial structures.”
- C) Commercial/Business Space shall be located in the front of the building. the
- D) Living Units shall be located in the rear of the building, ~~with main egress to be in the rear of the building.~~
- E) Living Space shall not exceed 50% of total **first floor** building space.

The Ad Hoc Committee presented proposed ordinance language on Storage Containers, Pods and Roll-Off Containers, to be drafted into proposed Ordinance# 201, for review at the next Ad Hoc committee meeting on March 20, 2024.

Discussion regarding "Building Compatible" Residential Homes (Pods/Tiny Houses) was introduced. Concerns voiced were building square footage, foundation types, walls and footings, dimensions of residential buildings, and zoning requirements.

The next scheduled Planning Commission Meeting shall be Wednesday, March 20, 2024, at 7:00 pm.

**Motion to adjourn the meeting at 7:19 pm was made by Oslund and supported by Rabideau.
Motion Carried.**

Respectfully submitted,

Nanette Walsh
Village Clerk/Treasurer



TO: Village Council
FROM: Debbie Powell, Village Manager
DATE: April 29, 2024
RE: April 2024 Manager's Message

Staff have been very busy making arrangements for the projects, activities, and events for the upcoming 2024 year. These include construction projects, recreation special events, capital investments, infrastructure, maintenance, and work on our strategic planning goals. Some of these require your council approval and will appear on the April agenda.

Other items of note to update the Village Council include the following.

DDA/Downtown Parking

The Downtown Development Authority (DDA) met on April 9, 2024 and set their 2024 goals. Their goals include downtown parking lot improvements, and are as follows:

1. Demolition of the DDA house located at Leach and Pine Streets
2. After demolition, parking lot improvements
3. Lease for the Cultural Center Building to the nonprofit Cass City Historical Cultural Center and Museum
4. Streetscape and Trees in the downtown corridor
5. Bicycle racks for the downtown

The Village retains asphalt millings from our street projects and stores them in the Industrial Park. The plan to improve the parking lot behind the businesses in the block behind Gilligans includes using those extra millings. The DDA would hire a contractor to pulverize and spread the millings to improve the surface area of the existing parking lot and where the house was located. This work is planned for 2024. The demolition has been contracted and the DDA is seeking a contractor for the remaining work.

Fairway/Former Coachlight Building

There has been a lot of interest recently from several developers in the Fairway Building. I have been in contact with the owner who has decided not to sell the building this year for personal reasons. We have an MEDC grant, with no in-kind match, in the amount of \$35,000 that I was promoting for pre-development of the Fairway Building. After discussion with MEDC, we will seek to offer this incentive for another project such as the Coachlight Building.

The Coachlight Building continues to be promoted by Rosegold Realty and is drawing interest from investors as the owners have lowered the price. It is only a matter of time before this property is under new ownership. I have been asked on multiple occasions about the zoning, incentives, grants, and tax abatements for this property. The Tuscola County EDC may also be able to offer assistance through their programs.

Frontier

Frontier has submitted four permit requests, to date, for extensive work they plan to do to upgrade their services and infrastructure in Cass City in 2024. RJ Klaus and I have reviewed the permits, maps, and specifications in the following locations: 1) alley behind the municipal building, 2) M-81 northern quadrant to Dale/Rose Streets, 3) south from M-81 to Elizabeth Street, and 4) Seeger Street intersections from Main Street to Hillcrest Drive.

The work includes placing buried and aerial fiber optic cable by HDD boring and over-lashing onto existing cable. The proposed dates for the work to be done are April through June.

Auditors

We are in year two of a three-year contract with our auditors, Anderson, Tuckey, Doran & Bernhardt, PC . The auditors are scheduled to be at the Municipal Building for on-site review the week of April 22, 2024. The work has been progressing well. The final audit will be presented to the Village Council on June 24, 2024 for your approval.

In other news, the Spring newsletter will be arriving in mailboxes the first week in May. The Municipal Building will be offering the brown yard waste bags free of charge to residents, they are currently on order and should be available in the next week. Happy Spring!

March winds bring April showers, April showers bring May flowers.

Robin Wallace

From: Laura Gaeth <laura.bafd@gmail.com>
Sent: Thursday, April 25, 2024 4:39 PM
To: Robin Wallace
Subject: Laura gaeth

Date: April 29, 2024

Hello and Good evening.

Cass City Village Council Meeting Animal Ordinance Gaeth Family Our names are Jason and Laura Gaeth. We live at 6766 Third Street. We have five children ages 26, 14, 12, 8 and 2. We purchased our place in 2011 . We loved this property for all the wonderful things it had to offer. The main selling point to us was the two acres and the barn. The front half was the city looking towards the street and the back half has a barn and a fenced area for animals. This property had Horses in the past and was part of twenty five acres, but since had been sectioned off.

When we bought this property we were told that we could have animals from the realtor. We made sure this was true and contacted The city Manager at the time Peter Cristiano, and he did say that our property could have farm animals and it used to have horses. Since then we have had multiple animals, chickens, goats, calves and rabbits.

We are asking Approval for our Domestic animals for your ordinance. We have had animals since we have been living here almost thirteen years . These animals are pets, they rely on us to take care of them and their wellbeing.

The animals we have are Wally- he is a Fainting goat, Flower a pygmy goat. Chickens- Pineapple, Mrs. Crow, Olive, rose, One Foot, Salt and Pepper.

These animals are dependent on our family to take care of them. We also depend on these animals for their constant love and support. Having these animals is teaching our children responsibility, learning about health and well being, empathy, creating bonds and relationships and most important respect for themselves.

Our Neighbors are well evolved with our animals. They want to feed them, they come over to pet and brush them. Some of our neighbors bring their grandchildren to pet and feed them.

My children help clean pens, and coops. They help the hoof trimmer trim goats hooves. My children and neighbors help collect eggs. My animals have been the high light to the day of a neighbor that is losing the battle to dementia. They have been on bike rides and wagon rides.

They are part of our family.

Any questions are welcome,

Thanks so much the

Gaeth Family Sent from my iPhone

Laura Gaeth
6766 3rd St.

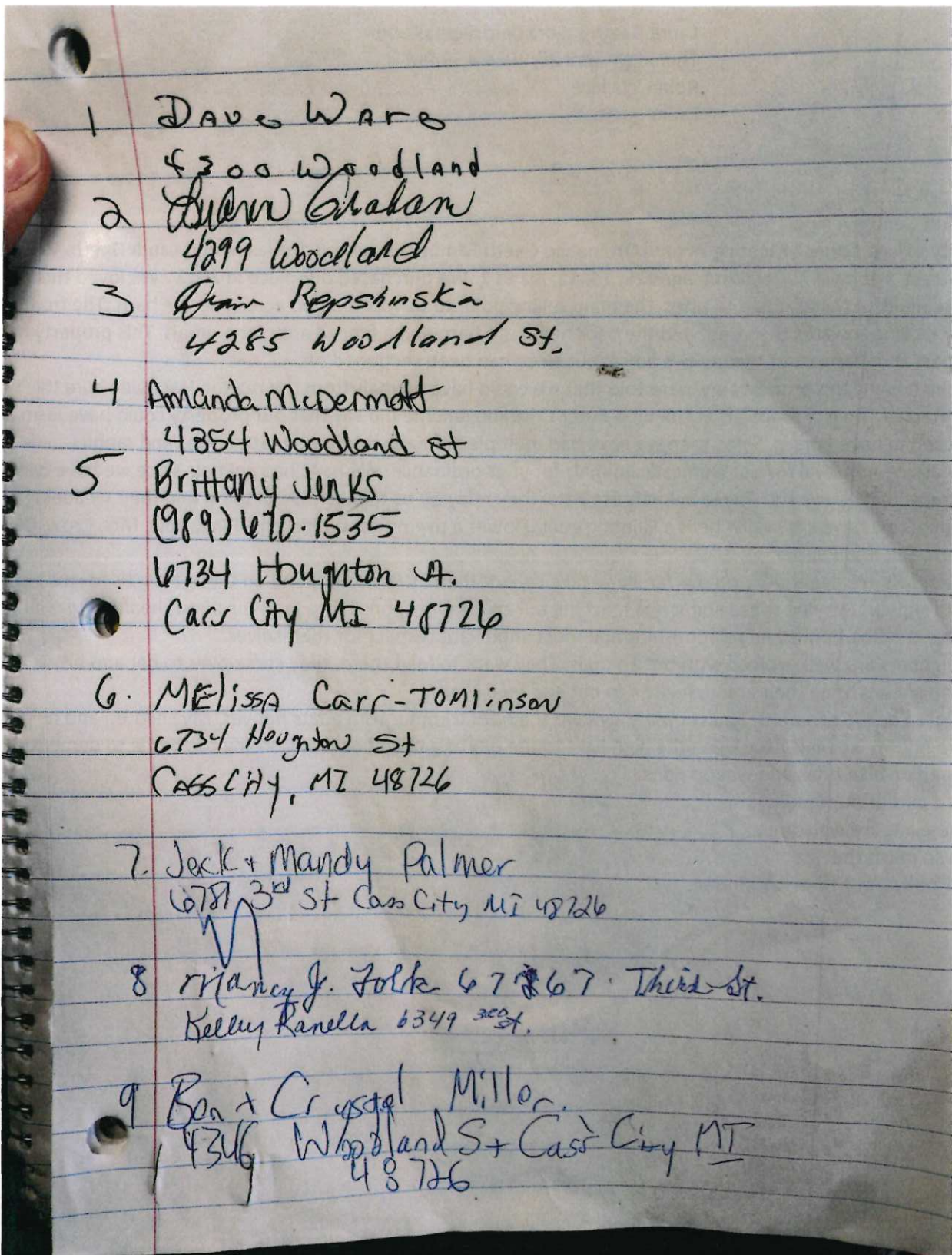

Here is the signatures from my neighbors approving my goats and my chickens . Hers a picture of my animals. I will send you my letter soon.

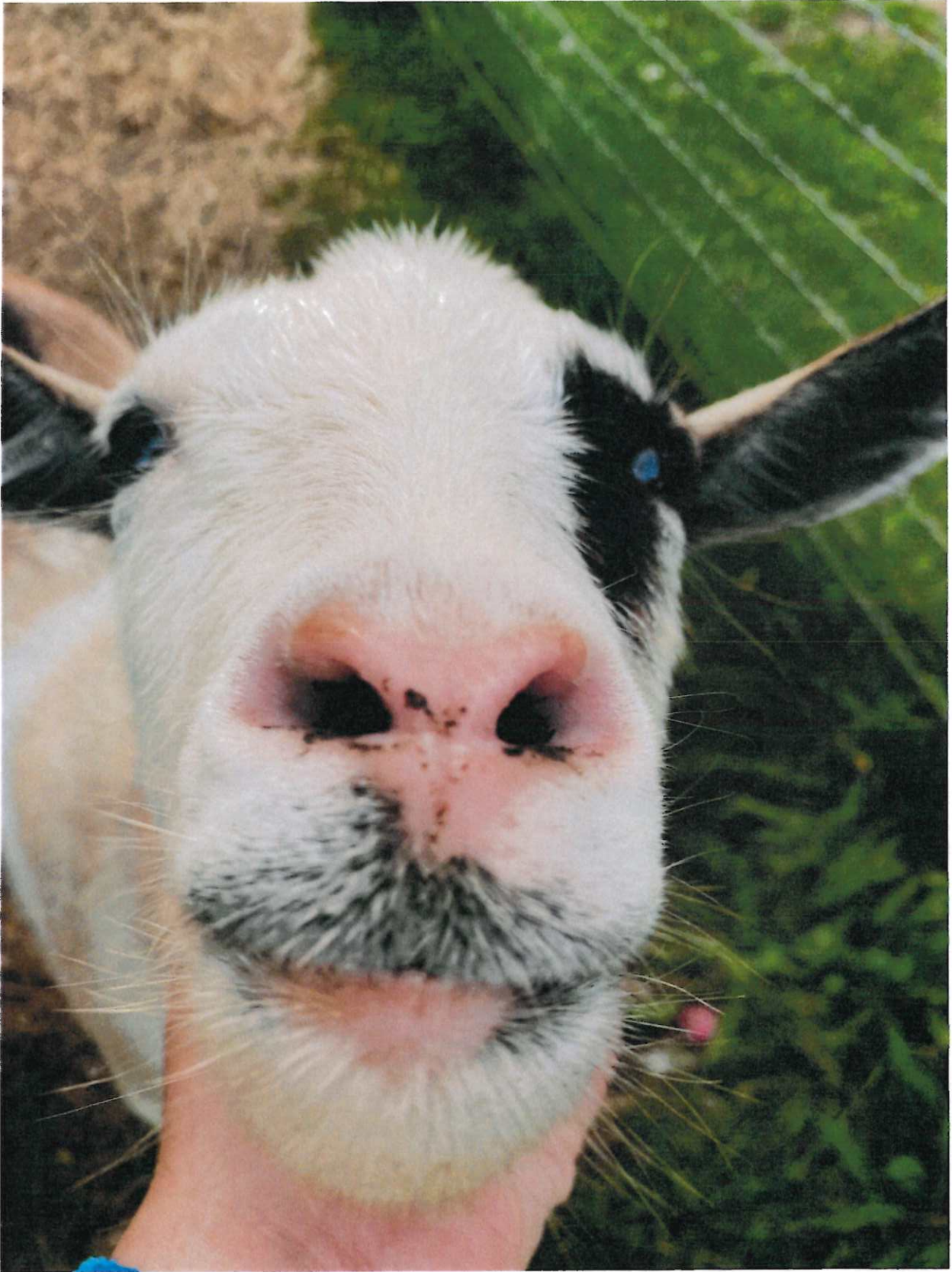





Per Village of Cass City regulations and discussion with representatives at City Hall, I, Drew Wessels and family, am informing all adjacent neighbors of my intentions to raise egg laying chickens.

1. Our family, your neighbor, intend to keep chickens in a caged coop and fenced area in our yard at 4859 Crestwood Dr in the County of Tuscola, Village of Cass City, Michigan for the purpose of providing more nutritious & healthy eggs and poultry products for family food consumption and garden fertilization.
2. Our family will be building an attractive/quality mobile coop & run sufficiently distant from all property lines that no debris would affect any neighbors property, and if visible, not be an eyesore.
3. Our family will be properly dealing with any/all chicken waste products in a manner to eliminate/avoid any noxious odors/debris affecting neighboring property owners.
4. Our family will be keeping all chickens enclosed within the coop until a reasonable hour daily and over night to prevent possible noise issues that might upset neighbors.
5. Our family will be making every effort to prevent or make it difficult to impossible for any chickens to "escape" or leave the property to enter neighboring properties.
6. Our family will remain open to future discussion with you regarding any issue the chickens are causing that may interfere with your enjoyment of your property and associated rights.
7. Neighbor/your signature(s) below indicate that they/you have been notified of my/our intention to own/house chickens on a neighboring property.

Signature *[Handwritten Signature]* Date 4-20-2024

Neighbor 1 Address 4857 Crestwood Dr. Name Karen Sweeney
(printed)

Signature *[Handwritten Signature]* Date 4-20-24

Neighbor 2 Address 6214 Beechwood Dr Name STEVE POLANS
(printed)

Signature *[Handwritten Signature]* Date 4-21-24



Moving Forward Working Together

Office of the Clerk/Treasurer
April 2024

Audit:

The Financial Audit Field Work was conducted on April 21-24, 2024, by Anderson, Tuckey, Bernhardt and Doran, LLC. Early indications forecast an increase to the fund balances. Significant activities were the conclusion of the Seeger Street Project, Cass City Dog Park, the Business Builders Grant, building reserves for the Arsenic Treatment Plant's filtration media replacement, Fishbeck Engineering for design of Wastewater Plant improvements and significant street projects.

When inquiring on best practices for fund balance levels, these suggestions are prudent for a Village with 2,474 population:

- Minimum Fund Balance Level: Equivalent to 3 months operating expenses.
Many State of Michigan payments have a 2-3 month turnaround period, such as Act 51 Streets, State Shared Revenues, Federal draw downs and smaller grants
- Suggested Fund Balance Level: Equivalent to 6 months operating expenses
A significant "rainy day fund" is needed as capital costs continue to rise, and can place a higher burden for smaller municipalities. Since the Village's fiscal year is January-December, and the Taxes are billed in July, the Village of Cass City needs a "Six Month Savings" to weather through the first half of the year.

The Cass City Financial Report is expected to be delivered at the June 24, 2024 Village Council meeting.

2024 Village Taxes

The Tuscola Equalization Department will be posting the 2024 Taxable Values for municipalities on their website any day. This data will allow the Village of Cass City to forecast its 2024 Tax Receivables as the Village Council will set Tax Levy Rates in May 2024.

Investments and Cash Flow

During March and April 2024, several Village of Cass City Certificates of Deposits (CDs) reached their maturity, and these CDs were liquidated to allow for positive cash flow for significant cash outflows during the same period. April 2024 had semi-annual bond payments to First Merchant Bank and USDA/Rural Development.



Fishbeck Engineering has done significant work for the Wastewater Treatment Plant improvements. Their monthly invoices are large, but planned for. We are utilizing the Village's ARPA funds and the allocation from Tuscola County to cover these costs. Attached, you will find a breakdown of how these ARPA funds were/are being spent.

2024 Village Elections:

Don't forget the November 5, 2024 election, where Village residents will have the opportunity to elect and/or re-elect its Village President (a two-year term), three 4-year trustee positions and a 2-year trustee position.

Deadline for **placing a candidate's name on the November 2024 ballot** is Tuesday, July 23, 2024, 4:00 pm to the Elkland Township Clerk or the Tuscola County Clerk.

Nanette Walsh, Clerk/Treasurer

How did VOCC Spend their ARPA Funds?

WWTP Engineering (Fishbeck) Paid to Date: (Screenshot of Accounts Payable Table for Fishbeck in 2023 and 2024)

FISHBECK	2,801.30	FISHBECK	10/16/2023	2,801.30	900658 428819	Y/900658
FISHBECK	12,340.10	FISHBECK	11/22/2023	12,340.10	900658 430027	Y/900658
FISHBECK	14,017.10	FISHBECK	12/11/2023	14,017.10	900658 430977	Y/900658
FISHBECK	44,760.70	FISHBECK	01/12/2024	44,760.70	900658 432297	Y/900658
FISHBECK	2,633.20	FISHBECK	01/12/2024	2,633.20	900658 432705	Y/900658
FISHBECK	46,048.90	FISHBECK	02/01/2024	46,048.90	900658 433221	Y/900658
FISHBECK	50,008.10	FISHBECK	03/01/2024	50,008.10	900658 434264	Y/900658
FISHBECK	45,165.00	FISHBECK	04/01/2024	45,165.00	900658 435237	Y/900658

Therefore:

2023 ARPA Expenditures: **76,552.40**

2024 ARPA Expenditures:

Paid through 4/24/2024: 141,222.00

JN A/P File for Pymt:

Inv#436456, 4/22/2024: 83,368.20

Total 2024 ARPA Expenditures: **224,590.20**

Total 2023 and 2024 ARPA Expenditures **301,142.60** ----> \$239,182 ARPA Funds to VOCC

61,960.60 ARPA Funds to TUSC CO \$250,000 Grant (Their ARPA)



Moving Forward, Working Together

COMMUNITY DEVELOPMENT SUMMARY APRIL 2024

- Applied for MEDC-Match on Main grant on behalf of Cass Theatre & Gilligan's.
- Marketing RFP's reviewed by sub-committee and presented to council 4-29-24.
- Engaged in Thumb Area Childcare Coalition committee via Zoom call.
- Continued participation in community economic engagement through various monthly meetings; DDA/EDC, L.E.A.D. Tuscola (steering committee representative at their class on 4-18), Cass City Chamber, Freedom Festival, Farmers Market.
- Continued retention/engagement visits with local businesses and outreach to new businesses.
- Participated in meeting w/ Senator Peters representatives regarding top goals for Cass City.
- Participated in webinar on Michigan Shared Streets & Spaces grant to explore bike racks downtown.
- Attending Rural Partners of Michigan Conference, 4-29 to 5-1 at Crystal Mountain.

PARKS & RECREATION SUMMARY APRIL 2024

- Grant awarded for new pool vacuum by TCCF FYI & Janks Funds.
- Day Camp handbook/registrations being promoted and are starting to come in (8 to date).
- Swim Lessons handbook completed and promoted; (35 registrations to date).
- Reviewed, contacted former seasonal staff, and promoted local Lifeguard certification classes.
- Interviewed CPR Aquatics of Caro for possible management contract for pool.
- Parks Supervisor returned 4-1-24, reviewed Spring projects list
- Collecting applications and work permits for interviewing seasonal pool and parks staff.
- Conducted monthly P&R meeting on 4-9-24.
- Researching costs on basketball court resurfacing/line striping.
- MANY event permits coming in for ball fields/tournaments; coordinating those on master calendar for P&R staff.
- Met with soccer league staff to determine fields needs for the Spring season.
- Met with Day Camp Coordinator to review seasonal plan and implementation.
- Lighting on Scotty McCollough Drive is up!

Submitted By: Melanie Radabaugh
Director of Community Development, Parks, and Recreation

VILLAGE OF CASS CITY
DEPARTMENT OF UTILITIES
VILLAGE COUNCIL SUMMARY REPORT
APRIL 2024

The following is a summary report for the activities that took place at the Wastewater Treatment Plant and Department of Public Works for the past month.

WASTEWATER TREATMENT PLANT

The Wastewater Treatment Plant Staff continue to work on items scheduled from the Preventative Maintenance Program.

Additional items that were completed:

- All three lift stations have been checked for routine maintenance.
- We have completed our monthly Selenium, chloride, and sulfate testing, and the data has been sent to the state.
- Collected and sent in our quarterly Mercury samples
- Also performed our Whole Effluent Toxicity mandated by NPDES permit
- The crew has continued to do general/routine maintenance around the plant.
- East RBC train is in full service, this will be in until onsite construction begins. At that point we will need to put the west train in service.
 - On April 1, upon routine inspection of plant equipment, the crew found that the 1st disc on the east train lost 1/3 of its air cups which are used to keep the disc turning. There is no easy or cheap fix to these discs. With anticipation of plant upgrades and the removal of this disc in the next year, we will continually monitor our lab numbers and adjust processes to keep the best treatment through the plant.
- Lab continuing water testing.
- Working with engineers on plant design.
- Licensing update
 - Steve Wright passed the Industrial Stormwater testing, it is a required license through the NPDES permit.

There were no violation of our NPDES permit for the month of March.

The average flows treated were: 318,000 gals/day for March 2024

286,000 gals/day for March 2023

DEPARTMENT OF UTILITIES

VILLAGE COUNCIL SUMMARY REPORT PAGE 2

DEPARTMENT OF PUBLIC WORKS

WATER DEPARTMENT

- **The Bacti samples and Arsenic samples were completed, and Water Reports filed as required by the MDEQ.**
- Al checked on high water bills
- Al/Kevin did miss digs for the month.
- The crew performed nonpayment shutoffs/turn-ons
- Continuing to work on LCR inventories.
- **The month of March 2024: The wells pumped 8.408 million gallons of water**
- **The average daily pumpage for March 2024: 271,000 gallons**
- **The average daily pumpage for March 2023: 264,000 gallons**

PUBLIC WORKS

- Performed routine maintenance on the Village Trucks and equipment.
- Continuing of street sweeping throughout town
- Patched streets around town
- Repaired a manhole of Rose St.
- Built up road along baseball fields with millings

Submitted by,

RJ Klaus

Director of Public Utilities

Cass City Police Department

6506 Main Street

P.O. Box 123

Cass City, Michigan 48726-0123

Phone: (989) 872-2911

Fax: (989) 872-4855

email: ccpdfreeman@casscity.org

April 26, 2024

Police Activity Report for April 2024

Calls for service in April 2024 (118 *complaints*) have *decreased* from March (179 *complaints*). It should be noted that the *monthly comparison* is 25 days to 31 days. In addition, the new code enforcement of signs in the Village Right of Way increased March's complaint numbers in comparison to other months.

Calls for service have increased in 2024 (596 complaints) from the same reporting period in 2023 (527 complaints).

Comparing the same reporting period in 2024 to 2023

- Assaults have *increased*.
- Burglary has *remained the same*.
- Larceny has *decreased*.
- Damage to Property has *remained the same*.
- Fraud has *decreased*.
- Traffic Crashes have *decreased*.
- Traffic and Parking Violations have *remained the same*.
- Family Offense-Other and Family-Child Abuse/Neglect have *decreased*.

Code/Ordinance Enforcement

The statistics/numbers below for 2024 **DO NOT** include open code violations from previous years.

- 19 properties with *Blight/Rubbish* violations.
- 24 *Vacant Properties*. We are continually updating and registering properties.
- 15 *Animal Complaints*.
- 0 *Golf Carts/ORV/ATV* traffic stops for non-compliance of ordinance.
- 32 *Inoperable Vehicle Ordinance* violations.
- 4 *Recreational Vehicle Storage* violations.
- 15 properties in violation of the *Grass/Weed Ordinance*.

Meetings

- Chief Freeman & Sgt Pierce – Village Council
- Chief Freeman – Tuscola County Chief's
- Sgt Pierce – Personnel & Public Safety
- Sgt Pierce – Child Advocacy Center of Tuscola County Board
- Sgt Pierce – LEAD Tuscola

Public Relations

- Sgt Pierce gave a speech about Child Abuse & Prevention to Great Start Tuscola

Significant Events

- Larceny of a Controlled Substance
- Embezzlement over \$5000
- Breaking & Entering
- Felony Domestic Violence
- Felonious Assault w/ a Knife

Offense Report

Report Criteria:

Start Date	End Date	Start Offense	End Offense	Status
01/01/2024	04/25/2024	99010	99010Z	ALL

Incident	Rprt Date	Description	Area	Officer	Status
<i>9901-0 -- VILLAGE ORDINANCE VIOLATION</i>					Count: 2
24-000282	02/27/2024	Illegal Burning - 4644 Oak St (J Bouck/A Grant)		PHILLIPS, KEVIN	Closed
24-000317	03/04/2024	Door to Door Solicitation - 4080 W Nicholas Dr (S Whipple)		FREEMAN, JAMES	Exceptional Clearance
<i>9901-0A -- ANIMALS</i>					Count: 15
24-000027	01/03/2024	Harboring Chickens - 4601 Huron St (S Anderson)		PHILLIPS, KEVIN	Open
24-000028	01/03/2024	Harboring Rabbits - 4545 Downing St (B Brown)		PHILLIPS, KEVIN	Open
24-000029	01/03/2024	Harboring Livestock - 6766 Third St (J Gaeth)		PHILLIPS, KEVIN	In Person Contact
24-000036	01/04/2024	Animal Complaint - 6177 Lakeside Dr (K Wells)		PIERCE, RYAN	Turned Over Animal Control
24-000058	01/09/2024	Dog @ Large - 4567 Seeger St (M Nelson)		FREEMAN, JAMES	Closed
24-000106	01/20/2024	Dog @ Large - 6601 Church St (D Clapsaddle)		SPANGLER, BRADLEY	Closed
24-000139	01/29/2024	Dog at Large/Neglect - Main St & Seeger St (T Sanford)		WAGNER, JEFFREY	Turned Over Animal Control
24-000204	02/11/2024	Sick Raccoon - 4581 Seeger St		PHILLIPS, KEVIN	Closed
24-000223	02/15/2024	Dog @ Large - Seeger St & Garfield Ave		PHILLIPS, KEVIN	Turned Over Animal Control
24-000276	02/26/2024	Dog Complaint - 6285 Main St (K Burch)		PIERCE, RYAN	Closed
24-000332	03/06/2024	Dog @ Large - Main St & Ale St (M Ziegler)		BOOMS, DANIELLE	Closed
24-000357	03/11/2024	Barking Dog - 6393 Chestnut Blvd (C Gilliam)		WAGNER, JEFFREY	Cleared by Citation
24-000465	03/27/2024	Dog @ Large - Main St & Leach St (E Hanby)		BOOMS, DANIELLE	Closed
24-000469	03/28/2024	Dog @ Large - Church St & Hill St (S Fortin)		BOOMS, DANIELLE	Closed
24-000540	04/16/2024	Dog At Large - Seeger St & Houghton St		PIERCE, RYAN	Closed
<i>9901-0B -- BLIGHT</i>					Count: 8
24-000005	01/02/2024	Blighted Structure - 6377 Seventh St (C Dotson)		PHILLIPS, KEVIN	Open
24-000006	01/02/2024	Blighted Structure - 6405 Sixth St (R Bean)		PHILLIPS, KEVIN	Open
24-000007	01/02/2024	Blighted Structure - 6359 Houghton St (A Remsing)		PHILLIPS, KEVIN	Cleared by Citation
24-000008	01/02/2024	Blighted Structure - 6306 Pine St (J Harmon)		PHILLIPS, KEVIN	Cleared by Citation
24-000244	02/21/2024	Blighted Structure - 6727 Pine St (A Zavitz)		PHILLIPS, KEVIN	Open
24-000423	03/19/2024	Blighted Structure - 6473 Main St (K Mooney)		PHILLIPS, KEVIN	Open
24-000448	03/25/2024	Blighted Structure - 6456 Third St (T Wright-Wismer)		PHILLIPS, KEVIN	Cleared by Citation
24-000485	04/02/2024	Blighted Structure - 4260 Seeger St (M Elwood)		PHILLIPS, KEVIN	Open
<i>9901-0D -- BRUSH IN STREET</i>					Count: 1
24-000504	04/09/2024	Grass Clippings in Roadway - Northwood Cir		PHILLIPS, KEVIN	Complied
<i>9901-0G -- GRASS/WEEDS</i>					Count: 15
24-000564	04/22/2024	Tall Grass/Weeds - 6285 Main St (K Burch)		PHILLIPS, KEVIN	Notice Mailed
24-000565	04/22/2024	Tall Grass/Weeds - 6229 Main St (S Seghatoleslami)		PHILLIPS, KEVIN	Notice Mailed
24-000566	04/22/2024	Tall Grass/Weeds - 6175 Main St (A Ozorowicz)		PHILLIPS, KEVIN	Notice Mailed
24-000567	04/22/2024	Tall Grass/Weeds - 6704 Main St (E Schaap)		PHILLIPS, KEVIN	Notice Mailed
24-000568	04/22/2024	Tall Grass/Weeds - 4545 Leach St (K Mooney)		PHILLIPS, KEVIN	Notice Mailed
24-000572	04/23/2024	Grass/Weeds/Rubbish - 6617 Main St (R Azzoo)		PHILLIPS, KEVIN	Notice Mailed
24-000573	04/23/2024	Tall Grass/Weeds - 6446 Pine St (K Spencer)		PHILLIPS, KEVIN	Notice Mailed
24-000574	04/23/2024	Tall Grass/Weeds - 6428 Pine St (D Mayer)		PHILLIPS, KEVIN	Notice Mailed
24-000575	04/23/2024	Tall Grass/Weeds - 6364 Pine St (C Crouch)		PHILLIPS, KEVIN	Notice Mailed
24-000576	04/23/2024	Tall Grass/Weeds - 6343 Pine St (M Parks)		PHILLIPS, KEVIN	Notice Mailed
24-000581	04/24/2024	Tall Grass/Weeds - 4326 Woodland Ave (P Smith)		PHILLIPS, KEVIN	Notice Mailed
24-000583	04/24/2024	Tall Grass/Weeds - 4260 Seeger St (M Elwood)		PHILLIPS, KEVIN	Notice Mailed
24-000584	04/24/2024	Tall Grass/Weeds - 4190 Leach St (G Fearson)		PHILLIPS, KEVIN	Notice Mailed

Offense Report

Report Criteria:

Start Date	End Date	Start Offense	End Offense	Status
01/01/2024	04/25/2024	99010	99010Z	ALL

Incident	Rprt Date	Description	Area	Officer	Status
24-000585	04/24/2024	Tall Grass/Weeds - 6392 Houghton St (A Magiera)		PHILLIPS, KEVIN	Notice Mailed
24-000587	04/24/2024	Tall Grass/Weeds - 6372 Pine St (D Francis)		PHILLIPS, KEVIN	Notice Mailed
<i>9901-0H -- RECREATIONAL VEHICLE STORAGE</i>					Count: 4
24-000211	02/12/2024	Recreational Storage - 6403 Beechwood Dr (E Hollis)		PIERCE, RYAN	Complied
24-000425	03/19/2024	Recreational Storage - 6312 Brenda Dr (M Moakes)		PHILLIPS, KEVIN	Complied
24-000449	03/25/2024	Recreational Storage - 4881 Hemlock Ln (D Vowel)		PHILLIPS, KEVIN	Open
24-000484	04/02/2024	Rubbish/Inoperable/Recreational/Zoning - 4509 Downing St (M Wilkins)		PHILLIPS, KEVIN	Unfounded
<i>9901-0J -- INOPERABLE VEHICLE</i>					Count: 38
24-000009	01/02/2024	Inoperable Vehicle/s - 6372 Fourth St (T Tietjens)		PHILLIPS, KEVIN	Complied
24-000010	01/02/2024	Inoperable Vehicle/s - 6324 Brenda Dr (D Macnall)		PHILLIPS, KEVIN	Complied
24-000011	01/02/2024	Inoperable Vehicle/s - 4325 Woodland Ave (D Peters)		PHILLIPS, KEVIN	Open
24-000012	01/02/2024	Inoperable Vehicle/s - 6811 Main St (J Root)		PHILLIPS, KEVIN	Complied
24-000013	01/02/2024	Inoperable Vehicle/s - 4259 Seeger St (N Hennessey)		PHILLIPS, KEVIN	Complied
24-000014	01/02/2024	Inoperable Vehicle/s - 4152 Sherman St (B Deering)		PHILLIPS, KEVIN	Complied
24-000015	01/02/2024	Inoperable Vehicle/s - 6725 Main St (B Griggs)		PHILLIPS, KEVIN	Complied
24-000016	01/02/2024	Inoperable Vehicle/s - 6785 Main St (J Bliss)		PHILLIPS, KEVIN	Complied
24-000023	01/02/2024	Inoperable Vehicle/s - 4312 Brenda Dr (C Arthur)		PHILLIPS, KEVIN	Complied
24-000031	01/03/2024	Inoperable Vehicle/s - 6165 Cedar Dr (N Cummins)		PHILLIPS, KEVIN	Complied
24-000033	01/04/2024	Inoperable Vehicle/s - 4391 Seeger St (K Turner)		PHILLIPS, KEVIN	Complied
24-000034	01/04/2024	Inoperable Vehicle/s - 4355 Leach St (P Tribble)		PHILLIPS, KEVIN	Complied
24-000057	01/09/2024	Inoperable Vehicle/s - 6455 Sixth St (R Boscaglia)		PHILLIPS, KEVIN	Complied
24-000060	01/09/2024	Inoperable Vehicle/s - 4534 West St (J Sherman)		PHILLIPS, KEVIN	Complied
24-000115	01/22/2024	Inoperable Vehicle/s - 6609 Seed St (T Fox)		PHILLIPS, KEVIN	Complied
24-000120	01/23/2024	Inoperable Vehicle/s - 4316 Doerr Rd (K Hillis)		PHILLIPS, KEVIN	Complied
24-000135	01/29/2024	Inoperable Vehicle/s - 6364 Pine St (C Crouch)		PHILLIPS, KEVIN	Complied
24-000136	01/29/2024	Inoperable Vehicle/s - 6306 Main St (C Koop)		PHILLIPS, KEVIN	Complied
24-000214	02/13/2024	Inoperable Vehicle/s - 4653 Hospital Dr (B Ramsay)		PHILLIPS, KEVIN	Complied
24-000217	02/14/2024	Inoperable Vehicle/s - 6780 Main St (G Mellendorf)		PHILLIPS, KEVIN	Complied
24-000222	02/15/2024	Inoperable Vehicle/s - 6667 Third St (S Wheaton)		PHILLIPS, KEVIN	Complied
24-000237	02/19/2024	Inoperable Vehicle/s - 6362 Fourth St (A Legualt)		PHILLIPS, KEVIN	Complied
24-000238	02/19/2024	Inoperable Vehicle/s - 6372 Fourth St (M Anderson)		PHILLIPS, KEVIN	Complied
24-000250	02/22/2024	Inoperable Vehicle/s - 4094 E Nicholas Dr (R Carpenter)		PHILLIPS, KEVIN	Complied
24-000271	02/26/2024	Inoperable Vehicle/s - 6379 Garfield Ave (K Romstad)		PHILLIPS, KEVIN	Open
24-000337	03/06/2024	Inoperable Vehicle/s - 6188 Lakeside Dr (A Bradley)		PHILLIPS, KEVIN	In Person Contact
24-000359	03/12/2024	Inoperable Vehicle/s - M St (D Matson)		PHILLIPS, KEVIN	Open
24-000361	03/12/2024	Inoperable Vehicle/s & Rubbish on Property - 6357 Main St (O McConnell)		PHILLIPS, KEVIN	Complied
24-000400	03/14/2024	Inoperable Vehicle/s - 6314 Main St (B Moakes)		PHILLIPS, KEVIN	Complied
24-000424	03/19/2024	Inoperable Vehicle/s - 6312 Brenda Dr (K Cross)		PHILLIPS, KEVIN	Complied
24-000426	03/19/2024	Inoperable Vehicle/s - 6188 Lakeside Dr (A Bradley)		PHILLIPS, KEVIN	In Person Contact
24-000431	03/20/2024	Inoperable Vehicle/s - 4409 Brooker St (R Bliss)		PHILLIPS, KEVIN	In Person Contact
24-000461	03/27/2024	Inoperable Vehicle/s - 6343 Pine St (M Parks/J Spencer)		PHILLIPS, KEVIN	Complied
24-000484	04/02/2024	Rubbish/Inoperable/Recreational/Zoning - 4509 Downing St (M Wilkins)		PHILLIPS, KEVIN	Unfounded
24-000487	04/02/2024	Inoperable Vehicle/s - 4394 Ale St (B Lefler)		PHILLIPS, KEVIN	In Person Contact
24-000511	04/09/2024	Inoperable Vehicle/s - 6772 Pine St (J Hennessey/M Harding)		PHILLIPS, KEVIN	Complied
24-000518	04/11/2024	Inoperable Vehicle/s - 6680 Third St (D Rabideau)		PHILLIPS, KEVIN	In Person Contact
24-000548	04/18/2024	Inoperable Vehicle/s - 4355 Leach St (P Tribble)		PHILLIPS, KEVIN	In Person Contact

Offense Report

Report Criteria:

Start Date	End Date	Start Offense	End Offense	Status
01/01/2024	04/25/2024	99010	99010Z	ALL

Incident	Rprt Date	Description	Area	Officer	Status
<i>9901-0L -- LOITERING</i>					Count: 2
24-000405	03/15/2024	Loitering - Express Stop (J McCoy)		PIERCE, RYAN	Closed
24-000542	04/16/2024	Loitering - Revive Ministries (R German)		PHILLIPS, KEVIN	Closed
<i>9901-0N -- UNNECESSARY NOISE</i>					Count: 1
24-000356	03/11/2024	Disturbing The Peace - 6609 Seed St (J Yax)		WAGNER, JEFFREY	Closed
<i>9901-0R -- RUBBISH/GARBAGE IN YARD</i>					Count: 11
24-000017	01/02/2024	Rubbish on Property - 4282 West St (J Howell)		PHILLIPS, KEVIN	Complied
24-000018	01/02/2024	Rubbish on Property - 4631 Oak St (M Hawk)		PHILLIPS, KEVIN	Complied
24-000019	01/02/2024	Rubbish on Property - 6318 Houghton St (C Mayer)		PHILLIPS, KEVIN	In Person Contact
24-000020	01/02/2024	Rubbish on Property - 6432 Church St (R Groth)		PHILLIPS, KEVIN	Complied
24-000124	01/24/2024	Rubbish on Property - 4319 West St (D Kingsland)		PHILLIPS, KEVIN	Complied
24-000335	03/06/2024	Rubbish on Property - 6249 Lakeside Dr (K Dishman)		PHILLIPS, KEVIN	Complied
24-000336	03/06/2024	Rubbish on Property - 6172 Lakeside Dr (A Swires)		PHILLIPS, KEVIN	Complied
24-000361	03/12/2024	Inoperable Vehicle/s & Rubbish on Property - 6357 Main St (O McConnell)		PHILLIPS, KEVIN	Complied
24-000457	03/26/2024	Rubbish on Property - 6343 Pine St (M Parks)		PHILLIPS, KEVIN	Complied
24-000484	04/02/2024	Rubbish/Inoperable/Recreational/Zoning - 4509 Downing St (M Wilkins)		PHILLIPS, KEVIN	Unfounded
24-000572	04/23/2024	Grass/Weeds/Rubbish - 6617 Main St (R Azzoo)		PHILLIPS, KEVIN	Notice Mailed
<i>9901-0V -- VACANT PROPERTY</i>					Count: 24
24-000163	02/05/2024	Vacant Property - 6215 Dale St (C Vandewater)		PIERCE, RYAN	Occupied
24-000164	02/05/2024	Vacant Property - 6306 Pine St (J Harmon)		PIERCE, RYAN	Notice Mailed
24-000165	02/05/2024	Vacant Property - 6327 Houghton St (G Binder)		PIERCE, RYAN	Notice Mailed
24-000166	02/05/2024	Vacant Property - 6359 Houghton St (A Remsing)		PIERCE, RYAN	Notice Mailed
24-000167	02/05/2024	Vacant Property - 6371 Houghton St (D Manchester)		PIERCE, RYAN	Registered
24-000168	02/05/2024	Vacant Property - 6571 Houghton St (Little B Properties)		PIERCE, RYAN	Notice Mailed
24-000169	02/05/2024	Vacant Property - 6456 Third St (T Wright-Wismer)		PIERCE, RYAN	Notice Mailed
24-000170	02/05/2024	Vacant Property - 6592 Third St (Little Provisions)		PIERCE, RYAN	Registered
24-000171	02/05/2024	Vacant Property - 6712 Third St (C Heckman)		PIERCE, RYAN	Registered
24-000172	02/05/2024	Vacant Property - 6395 Fourth St (P Astley)		PIERCE, RYAN	Notice Mailed
24-000173	02/05/2024	Vacant Property - 6606 Garfield Ave (B Beeman)		PIERCE, RYAN	Notice Mailed
24-000174	02/05/2024	Vacant Property - 6721 Garfield Ave (R Voss)		PIERCE, RYAN	Notice Mailed
24-000175	02/05/2024	Vacant Property - 6377 Seventh St (C Dotson)		PIERCE, RYAN	Registered
24-000176	02/05/2024	Vacant Property - 4319 Seeger St (MI State Housing)		PIERCE, RYAN	Notice Mailed
24-000177	02/05/2024	Vacant Property - 4331 Seeger St (N Nicol)		PIERCE, RYAN	Notice Mailed
24-000178	02/05/2024	Vacant Property - 4386 Seeger St (G Standeford)		PIERCE, RYAN	Notice Mailed
24-000179	02/05/2024	Vacant Property - 4594 Seeger St (R Parrish)		PIERCE, RYAN	Registered
24-000180	02/05/2024	Vacant Property - 4594 Oak St (Y Greer)		PIERCE, RYAN	Registered
24-000181	02/05/2024	Vacant Property - 4215 Maple St (B Hennessey)		PIERCE, RYAN	Notice Mailed
24-000182	02/05/2024	Vacant Property - 4325 Sherman St (B Hennessey)		PIERCE, RYAN	Notice Mailed
24-000183	02/05/2024	Vacant Property - 4665 Hospital Dr (L Ross/D Delamarter)		PIERCE, RYAN	Registered
24-000184	02/05/2024	Vacant Property - 4656 Hunt St (K Hool)		PIERCE, RYAN	Registered
24-000185	02/05/2024	Vacant Property - 6603 Huron Ave (J Ricker)		PIERCE, RYAN	Notice Mailed
24-000186	02/05/2024	Vacant Property - 6628 Seed St (L Peterson)		PIERCE, RYAN	Notice Mailed
<i>9901-0W -- WASTE COLLECTION</i>					Count: 13
24-000320	03/04/2024	Waste Collection - 6535 Main St (Horizon Properties, LLC)		PHILLIPS, KEVIN	Complied
24-000420	03/18/2024	Waste Collection - 6403 Beechwood Dr (E Hollis)		PHILLIPS, KEVIN	Open

Offense Report

Report Criteria:

Start Date	End Date	Start Offense	End Offense	Status
01/01/2024	04/25/2024	99010	99010Z	ALL

Incident	Rprt Date	Description	Area	Officer	Status
24-000428	03/20/2024	Waste Collection - 6725 Main St (S Griggs)		PHILLIPS, KEVIN	Open
24-000455	03/26/2024	Garbage Collection - 6352 Main St (D Krantz)		PHILLIPS, KEVIN	Open
24-000456	03/26/2024	Garbage Collection - 4408 West St (A Remsing)		PHILLIPS, KEVIN	Open
24-000490	04/02/2024	Waste Collection - 6681 Third St (M Krueger)		PHILLIPS, KEVIN	Open
24-000505	04/09/2024	Waste Collection - 6545 Church St (Henchmen MC Clubhouse)		PHILLIPS, KEVIN	Open
24-000506	04/09/2024	Waste Collection - 6373 Sixth St (S Kokenos)		PHILLIPS, KEVIN	Open
24-000507	04/09/2024	Waste Collection - 6291 Church St (S Adams)		PHILLIPS, KEVIN	Open
24-000508	04/09/2024	Waste Collection - 4454 Sherman St (S Mousseau)		PHILLIPS, KEVIN	In Person Contact
24-000509	04/09/2024	Waste Collection - 4446 Sherman St (V Haag)		PHILLIPS, KEVIN	Open
24-000510	04/09/2024	Waste Collection - 6728 Houghton St (J Woodall)		PHILLIPS, KEVIN	Open
24-000563	04/22/2024	Waste Collection - 4316 Doerr Rd (J Wilson)		PHILLIPS, KEVIN	Open

9901-0X -- SIGNS Count: 44

24-000368	03/14/2024	Sign/s in Right of Way - 6567 Church St (C Williamson)		PHILLIPS, KEVIN	Complied
24-000369	03/14/2024	Sign/s in Right of Way - 6417 Church St (K McClorey)		PHILLIPS, KEVIN	Open
24-000370	03/14/2024	Sign/s in Right of Way - 6291 Church St (S Adams)		PHILLIPS, KEVIN	Pending Renewal
24-000371	03/14/2024	Sign/s in Right of Way - 4567 Seeger St (M Nelson)		PHILLIPS, KEVIN	Pending Renewal
24-000372	03/14/2024	Sign/s in Right of Way - 4790 Hospital Dr (Meritage Mgt)		PHILLIPS, KEVIN	Complied
24-000373	03/14/2024	Sign/s in Right of Way - 4572 Hills St (Meritage Mgt)		PHILLIPS, KEVIN	Complied
24-000374	03/14/2024	Sign/s in Right of Way - Parcel 035-028-000-2420-00 (Northwood Lake Condo Assc)		PHILLIPS, KEVIN	Pending Renewal
24-000375	03/14/2024	Sign/s in Right of Way - 6445 Garfield Ave (M Grider)		PHILLIPS, KEVIN	Complied
24-000376	03/14/2024	Sign/s in Right of Way - Houghton St & Seeger St (Church of God)		PHILLIPS, KEVIN	Closed
24-000377	03/14/2024	Sign/s in Right of Way - Houghton St & Seeger St (First Baptist Church)		PHILLIPS, KEVIN	Closed
24-000378	03/14/2024	Sign/s in Right of Way - 4334 Seeger St (C Erla)		PHILLIPS, KEVIN	Complied
24-000379	03/14/2024	Sign/s in Right of Way - 4319 Seeger St (HUD)		PHILLIPS, KEVIN	Pending Renewal
24-000380	03/14/2024	Sign/s in Right of Way - 6242 Garfield Ave (Walbro)		PHILLIPS, KEVIN	Complied
24-000381	03/14/2024	Sign/s in Right of Way - 4401 Brooker St (R Simpson)		PHILLIPS, KEVIN	Complied
24-000382	03/14/2024	Sign/s in Right of Way - 6340 Houghton St (G Wilson)		PHILLIPS, KEVIN	Pending Renewal
24-000383	03/14/2024	Sign/s in Right of Way - 6338 Main St (D Howard)		PHILLIPS, KEVIN	Complied
24-000384	03/14/2024	Sign/s in Right of Way - 6742 Main St (M Ziegler)		PHILLIPS, KEVIN	Complied
24-000385	03/14/2024	Sign/s in Right of Way - 6658 Huron St (T Vatter)		PHILLIPS, KEVIN	Pending Renewal
24-000386	03/14/2024	Sign/s in Right of Way - 6401 Huron St (J Blattner)		PHILLIPS, KEVIN	Complied
24-000387	03/14/2024	Sign/s in Right of Way - 4385 Doerr Rd (W Harrington)		PHILLIPS, KEVIN	Closed
24-000388	03/14/2024	Sign/s in Right of Way - Parcel 035-033-000-4530-00 (A Wright Trust)		PHILLIPS, KEVIN	Pending Renewal
24-000389	03/14/2024	Sign/s in Right of Way - 6291 Virginia St (E Read)		PHILLIPS, KEVIN	Complied
24-000390	03/14/2024	Sign/s in Right of Way - 4309 Woodland Ave (R Wallace)		PHILLIPS, KEVIN	Pending Renewal
24-000391	03/14/2024	Sign/s in Right of Way - 6721 Garfield Ave (E Montreuil)		PHILLIPS, KEVIN	Pending Renewal
24-000392	03/14/2024	Sign/s in Right of Way - 6809 Herron Dr (G Jones)		PHILLIPS, KEVIN	Complied
24-000393	03/14/2024	Sign/s in Right of Way - 4311 Ale St (M Yax)		PHILLIPS, KEVIN	Pending Renewal
24-000394	03/14/2024	Sign/s in Right of Way - 4273 Sherman St (C Diaz)		PHILLIPS, KEVIN	Complied
24-000395	03/14/2024	Sign/s in Right of Way - 4325 Sherman St (B Hennessey)		PHILLIPS, KEVIN	Pending Renewal
24-000396	03/14/2024	Sign/s in Right of Way - 6374 Chestnut Blvd (J Dombey)		PHILLIPS, KEVIN	Complied
24-000397	03/14/2024	Sign/s in Right of Way - 6241 Main St (Independent Bank)		PHILLIPS, KEVIN	Closed
24-000398	03/14/2024	Sign/s in Right of Way - 6180 Main St (Unknown)		PHILLIPS, KEVIN	Closed
24-000399	03/14/2024	Sign/s in Right of Way - 6254 Main St (T Moore)		PHILLIPS, KEVIN	Complied
24-000406	03/15/2024	Sign/s in Right of Way - 6538 Third St (Church of Nazarene Bldg)		PHILLIPS, KEVIN	Pending Renewal
24-000418	03/18/2024	Sign/s in Right of Way - 6325 Main St (P Pasternak)		PHILLIPS, KEVIN	Complied

Offense Report

Report Criteria:

Start Date	End Date	Start Offense	End Offense	Status
01/01/2024	04/25/2024	99010	99010Z	ALL

Incident	Rprt Date	Description	Area	Officer	Status
24-000430	03/20/2024	Sign/s in Right of Way - 6440 Huron St (M Karwowski)		PHILLIPS, KEVIN	Complied
24-000458	03/26/2024	Sign/s in Right of Way - Seeger St & Garfield Ave (Osentoski Reality)		PHILLIPS, KEVIN	Complied
24-000480	04/01/2024	Sign/s in Right of Way - 4545 Leach St (K Mooney)		PHILLIPS, KEVIN	Complied
24-000494	04/03/2024	Sign/s in Right of Way - MiTech Tooling, Inc		PHILLIPS, KEVIN	Closed
24-000501	04/08/2024	Sign/s in Right of Way - Beechwood Dr & Hospital Dr (Northwood Lake Condos Asc)		PHILLIPS, KEVIN	Closed
24-000513	04/10/2024	Sign/s in Right of Way - 6386 Garfield Ave (G Thane)		PHILLIPS, KEVIN	Complied
24-000520	04/11/2024	Sign/s in Right of Way - 6720 Third St (Elite Reality)		PHILLIPS, KEVIN	Pending Renewal
24-000521	04/11/2024	Sign/s in Right of Way - 6757 Main St		PHILLIPS, KEVIN	Complied
24-000522	04/11/2024	Sign/s in Right of Way - 4309 Woodland Ave		PHILLIPS, KEVIN	Complied
24-000571	04/22/2024	Sign/s in Right of Way - 6681 Third St (M Krueger)		PHILLIPS, KEVIN	Open
<i>9901-0Z -- ZONING</i>					Count: 4
24-000334	03/06/2024	Building Permit - 6430 Chestnut Blvd		FREEMAN, JAMES	Turned Over
24-000484	04/02/2024	Rubbish/Inoperable/Recreational/Zoning - 4509 Downing St (M Wilkins)		PHILLIPS, KEVIN	Unfounded
24-000544	04/16/2024	Zoning - 4716 Hunt St (J Smentek)		PHILLIPS, KEVIN	Complied
24-000570	04/22/2024	Building Permit - 6433 Church St (K Russell)		PHILLIPS, KEVIN	Turned Over Building Codes

Total: 182

Offense Activity Counts

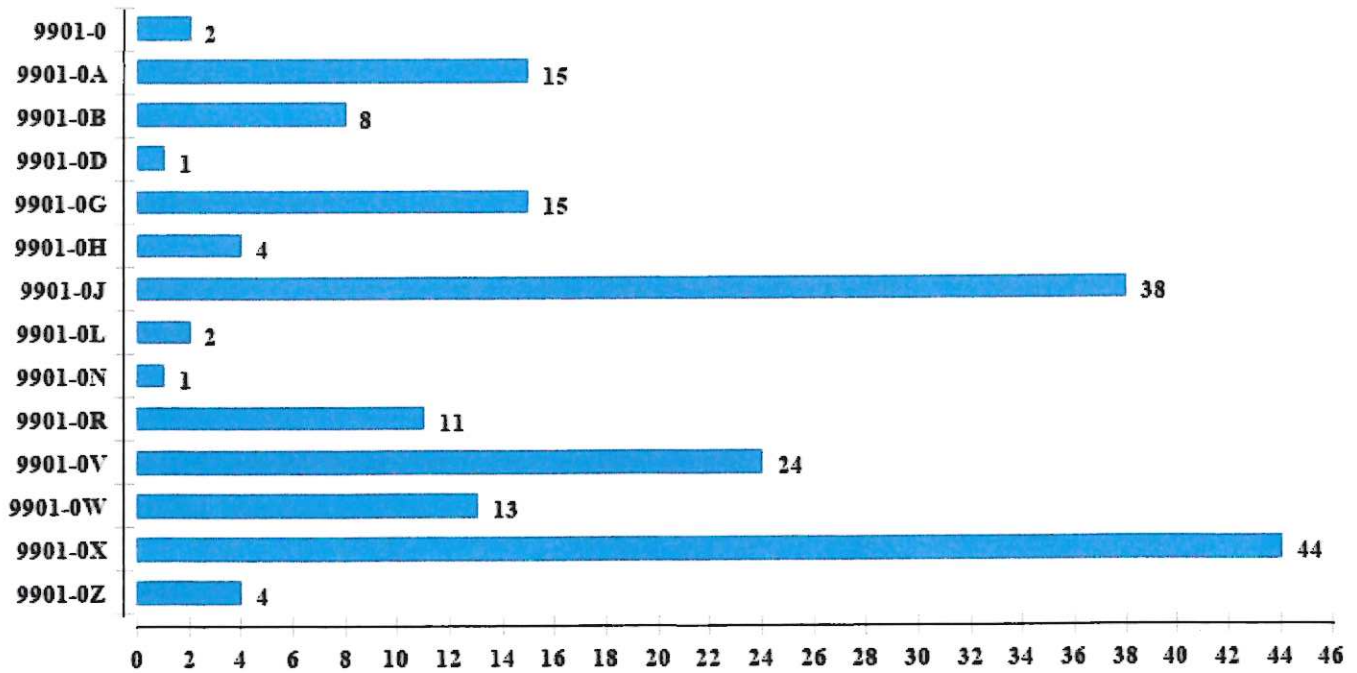

Offense Count Report

Report Criteria:

Start Offense	End Offense	Officer
01000	PTL	ALL
2024	2023	
01/01/2024-04/25/2024	01/01/2023-04/25/2023	

Offense	Description	2024	2023
11007	SEXUAL CONTACT FORCIBLE - CSC 2ND DEGREE	0	1
13001	NONAGGRAVATED ASSAULT	8	6
13002	AGGRAVATED/FELONIOUS ASSAULT	1	0
13003	INTIMIDATION/STALKING	7	5
21000	EXTORTION	0	2
23003	LARCENY - THEFT FROM A BUILDING	1	2
23007	LARCENY - OTHER	3	3
24001	MOTOR VEHICLE THEFT	0	1
26001	FRAUD - FALSE PRETENSE/SWINDLE/CONFIDENCE GAME	3	3
26002	FRAUD - CREDIT CARD/AUTOMATIC TELLER MACHINE	2	1
26003	FRAUD - IMPERSONATION	0	1
26007	FRAUD - IDENTITY THEFT	1	1
26008	FRAUD - HACKING/COMPUTER INVASION	0	1
27000	EMBEZZLEMENT	1	0
29000	DAMAGE TO PROPERTY	4	4
30002	RETAIL FRAUD - THEFT	2	0
35001	VIOLATION OF CONTROLLED SUBSTANCES ACT	2	1
36004	SEX OFFENCE - OTHER	2	2
38001	FAMILY - CHILD ABUSE/NEGLECT NONVIOLENT	0	2
38003	OTHER FAMILY OFFENSE	4	7
41002	LIQUOR VIOLATIONS - OTHER	0	1
48000	OBSTRUCTING POLICE	0	1
50000	OBSTRUCTING JUSTICE	10	6
53001	DISORDERLY CONDUCT	6	2
53002	PUBLIC PEACE - OTHER	1	0
54001	HIT AND RUN MOTOR VEHICLE ACCIDENT	1	1
54002	OPERATING UNDER THE INFLUENCE OF LIQUOR OR DRUGS	6	3
54003	TRAFFIC OFFENSE	18	23
55000	HEALTH AND SAFETY	6	5
57001	TRESPASS	1	1
70000	JUVENILE RUNAWAY	0	2
72000	ANIMAL CRUELTY	0	1
73000	MISCELLANEOUS CRIMINAL OFFENCE	1	3
91001	DELINQUENT MINORS	2	4
92002	INCAPACITATION	0	1
92004	INSANITY	3	3
93001	TRAFFIC CRASH	4	4
93002	NONTRAFFIC CRASH	2	5
93003	TRAFFIC VIOLATION - CIVIL	37	37
93004	PARKING	56	76
93006	TRAFFIC POLICING	31	14
93007	TRAFFIC SAFETY	6	3
93008	BREATHALYZER INSPECTION	3	4
94001	VALID ALARM ACTIVATION	0	1
94002	FALSE ALARM ACTIVATION	6	13

Offense Count Report

Report Criteria:

Start Offense	End Offense	Officer
01000	PTL	ALL
2024	2023	
01/01/2024-04/25/2024	01/01/2023-04/25/2023	

Offense	Description	2024	2023
98002	INVESTIGATION - VEHICLE	1	1
98003	PROPERTY INSPECTION	3	3
98004	OTHER INSPECTION	36	38
98005	UNFOUNDED ALARM	0	1
98006	CIVIL MATTER	16	17
98007	SUSPICIOUS SITUATION	30	15
98008	FOUND/LOST PROPERTY	9	7
99001	SUICIDE OR ATTEMPT	3	4
99002	NATURAL DEATH	0	2
99003	MISSING PERSON	0	2
99007	PUBLIC RELATIONS	1	4
99008	GENERAL ASSISTANCE-NON POLICE AGENCY	41	38
99009	GENERAL NON-CRIMINAL	5	11
99010	VILLAGE ORDINANCE VIOLATION	2	1
99010A	ANIMALS	15	10
99010B	BLIGHT	8	0
99010D	BRUSH IN STREET	1	1
99010G	GRASS/WEEDS	15	3
99010H	RECREATIONAL VEHICLE STORAGE	4	4
99010J	INOPERABLE VEHICLE	38	37
99010L	LOITERING	2	1
99010N	UNNECESSARY NOISE	1	2
99010R	RUBBISH/GARBAGE IN YARD	11	8
99010S	SNOWMOBILES	0	1
99010T	ORV/ATV	0	3
99010V	VACANT PROPERTY	24	24
99010W	WASTE COLLECTION	13	0
99010X	SIGNS	44	0
99010Z	ZONING	4	2
99011	CURFEW VIOLATION	1	0
99013	ASSIST TO ANOTHER POLICE AGENCY	25	28
99911	911 HANGUP CALL	2	2
Totals:		596	527

Offense Count Report

Report Criteria:

Start Offense	End Offense	Officer
01000	PTL	ALL
APRIL	MARCH	
04/01/2024-04/25/2024	03/01/2024-03/31/2024	

Offense	Description	APRIL	MARCH
13001	NONAGGRAVATED ASSAULT	1	1
13002	AGGRAVATED/FELONIOUS ASSAULT	1	0
13003	INTIMIDATION/STALKING	0	1
23003	LARCENY - THEFT FROM A BUILDING	0	1
23007	LARCENY - OTHER	1	1
26001	FRAUD - FALSE PRETENSE/SWINDLE/CONFIDENCE GAME	1	0
26002	FRAUD - CREDIT CARD/AUTOMATIC TELLER MACHINE	0	1
27000	EMBEZZLEMENT	1	0
29000	DAMAGE TO PROPERTY	1	3
30002	RETAIL FRAUD - THEFT	1	0
35001	VIOLATION OF CONTROLLED SUBSTANCES ACT	1	1
38003	OTHER FAMILY OFFENSE	1	2
50000	OBSTRUCTING JUSTICE	3	2
53001	DISORDERLY CONDUCT	2	2
53002	PUBLIC PEACE - OTHER	1	0
54001	HIT AND RUN MOTOR VEHICLE ACCIDENT	0	1
54002	OPERATING UNDER THE INFLUENCE OF LIQUOR OR DRUGS	0	2
54003	TRAFFIC OFFENSE	5	7
55000	HEALTH AND SAFETY	2	0
91001	DELINQUENT MINORS	1	1
92004	INSANITY	1	1
93001	TRAFFIC CRASH	0	1
93002	NONTRAFFIC CRASH	0	1
93003	TRAFFIC VIOLATION - CIVIL	4	13
93004	PARKING	2	7
93006	TRAFFIC POLICING	4	12
93007	TRAFFIC SAFETY	3	3
93008	BREATHALYZER INSPECTION	0	1
94002	FALSE ALARM ACTIVATION	2	2
98002	INVESTIGATION - VEHICLE	0	1
98004	OTHER INSPECTION	7	10
98006	CIVIL MATTER	4	3
98007	SUSPICIOUS SITUATION	7	9
98008	FOUND/LOST PROPERTY	1	2
99001	SUICIDE OR ATTEMPT	0	2
99008	GENERAL ASSISTANCE-NON POLICE AGENCY	7	13
99009	GENERAL NON-CRIMINAL	2	0
99010	VILLAGE ORDINANCE VIOLATION	0	1
99010A	ANIMALS	1	4
99010B	BLIGHT	1	2
99010D	BRUSH IN STREET	1	0
99010G	GRASS/WEEDS	15	0
99010H	RECREATIONAL VEHICLE STORAGE	1	2
99010J	INOPERABLE VEHICLE	5	8
99010L	LOITERING	1	1

Offense Count Report

Report Criteria:

Start Offense	End Offense	Officer
01000	PTL	ALL
APRIL	MARCH	
04/01/2024-04/25/2024	03/01/2024-03/31/2024	

Offense	Description	APRIL	MARCH
99010N	UNNECESSARY NOISE	0	1
99010R	RUBBISH/GARBAGE IN YARD	2	4
99010W	WASTE COLLECTION	8	5
99010X	SIGNS	8	36
99010Z	ZONING	3	1
99013	ASSIST TO ANOTHER POLICE AGENCY	4	7
99911	911 HANGUP CALL	1	0
Totals:		118	179



TUSCOLA COUNTY
ECONOMIC DEVELOPMENT CORP

Empowering Leaders in Agriculture, Manufacturing, and Clean Energy

141 S Almer St, Caro, MI 48723 • (989) 673 - 2849 • www.tuscolacountyedc.org • mclinesmith@tuscolaedc.org

April 11, 2024

Debbie Powell, Village Manager
Village of Cass City
6506 Main Street
Cass City, MI 48726

Dear Debbie Powell and Cass City Village Council,

On behalf of the Tuscola County Economic Development Corporation Board of Directors, thank you for your \$7,500 allocation to the EDC.

We appreciate working with you to provide resources to develop Tuscola County businesses and municipalities. This funding allows us to provide services to our local business through our grant and loan programs, encourage business development through commercial and industrial tax exemption programs, redevelop blighted property through brownfield programs, apply for and administer grants that benefit both business owners and municipalities. These services provide a win-win result for Cass City and all of Tuscola County.

As we continue to work on these programs, let us know if you have any questions or need assistance with any of our services. The EDC looks forward to more progress being made on major redevelopment of the Nestle's Building.

You and your staff have always been friends of the EDC. We look forward to continuing this public-private partnership for a long time to come.

Thank you,

Michael Clinesmith
Grant Administrator



Association of Public Treasurers
of the United States and Canada

EXECUTIVE BOARD

TRICIA WIGGLE-BAZZY
PRESIDENT

VICKI KITCHEN
PRESIDENT ELECT

HEATHER GALE
VICE PRESIDENT

ERIN CRAWFORD
TREASURER

SALVATORE TALARICO
SECRETARY

JULIE SILBERNAGEL
IMMEDIATE PAST
PRESIDENT

DIRECTORS

SUSAN BALLS

PETER GRAY

LINDSEY GRIGG-MOAK

CHARRI LARA

VERNON LEWIS

DAVID SEIFERT

LAURIE SHELDON

ADVISORS

CLINT LICHTENWALTER

MICHAEL PETTIGREW

PARLIAMENTARIAN

CHELSEA PETERSON

HISTORIAN

BLINDA BAKER

March 25, 2024

Nanette Walsh, CPFA
Village of Cass City
Post Office Box 123
Cass City, Michigan 48726

Dear Nanette:

On behalf of the Association of Public Treasurers of the United States and Canada, (APT US&C), I am pleased to award you re-certification of the professional credential of Certified Public Finance Administrator (CPFA). This honor reinforces the primary purpose of APT US&C - to elevate the level of knowledge of public finance and enrich the performance within the treasury management profession.

Your plaque will be mailed to you in the coming weeks to proudly display in your office as a testament to your commitment to your profession and your community. We hope you display this award with great pride in knowing how hard you worked to maintain your CPFA.

If you have any questions regarding your Certification, please don't hesitate to contact the Association at 989-820-5205 or info@aptusc.org.

Congratulations Nanette!

Sincerely,

Blinda A. Baker, ACPFA
Chair, CPFA Certification Committee

Please note: Your CPFA Certification will expire June 1, 2029. To maintain this credential, you must be a member of the Association continuously for the five consecutive years that immediately follow the certification, must earn the necessary points for re-certification in any combination of Education and Experience Maintenance Standards and return your maintenance application prior to June 1, 2029.

CLOSED SESSION

Confidential

**Materials provided
under separate cover
to Village Council.**

